

NO. E1AR-1901

ISSUED: MAR. 1997

REVISED: DEC. 2011



**HOSHIZAKI**  
**SELF-CONTAINED CUBER**

MODEL **IM-65WLE**  
**IM-65WLE-25**

**PARTS LIST**

[ HE , GENERAL (50Hz) , EXPORT (60Hz) , KOREA , RINNAI , OCEANIA ]

G-1	MAR. 1997	D-1	MAR. 2004	V-0	JAN. 2010
H-0	DEC. 1997	D-2	NOV. 2004	L-0	JAN. 2011
H-1	MAR. 1998	E-0	DEC. 2004		
J-0	DEC. 1998	E-1	APR. 2005		
K-0	DEC. 1999	E-2	NOV. 2005		
K-1	FEB. 2000	F-0	DEC. 2005		
A-0	DEC. 2000	G-01	JAN. 2007		
B-1	DEC. 2001	G-11	JUL. 2007		
C-0	DEC. 2002	H-11	JAN. 2008		
C-1	OCT. 2003	T-1	MAY. 2008		
D-0	DEC. 2003	U-0	JAN. 2009		

# MATERIAL ABBREVIATIONS

## ALUMINUM

AL = Aluminum

## COPPER

CU = Copper

## PLASTIC

ABS = Acrylonitrile -butadiene - styrene  
AC = Polyacetal  
EVA = Ethylene vinyl acetate  
PA = Polyamide = Nylon  
PC = Polycarbonate  
PE = Polyethylene  
PES = Polyester  
PETP = Polyethylene terephthalate = Tetlon  
PP = Polypropylene  
PS = Polystyrene  
PTFE = Polytetrafluoroethylene = Teflon  
PUR = Polyurethane  
PVC = Polyvinyl chloride

## RUBBER

VN = Vinyl Nitrile  
EPDM = EP rubber  
NBR = Nitrile butadiene rubber  
NR = Natural rubber  
NP = Neoprene  
SI.R = Silicone rubber  
SY.R = Synthetic rubber  
EPH = Epichlorohydrin

## STEEL

GS = Galvanized steel  
SS = Stainless steel  
PS = Plated steel  
PAS = Primed steel

## AUXILIARY CODE

K-0

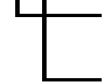

Designates the year. "K" indicates the year 2000. Years progress or regress in alphabetical order. "J" is 1999, "L" is 2001, "M" is 2002, and so on. The letters "I" and "O" were skipped.

Designates significant part changes within the same year. Base is 0 and this number advances for each change.

Example: P-1



"P" indicates 2004.

"1" indicates the first significant part change for 2004.

## MARKS LOCATED UNDER THE AUXILIARY CODE

- = Part deleted.
- x = Part deleted and replaced by "o" part.
- o = New part in place of "x" part.

## FASTENER ABBREVIATION LIST

ST	=	Phillips Truss Head Machine Screw
SP	=	Phillips Pan Head Machine Screw
SF	=	Phillips Flat Head Machine Screw
SS	=	Phillips Pan Head Machine Screw with Split Lock Washer
SW	=	Phillips Pan Head Machine Screw with Split Lock Washer and Flat Washer
T1	=	Phillips Truss Head Tapping Screw (Correspond to Type A)
T2	=	Phillips Truss Head Tapping Screw (Correspond to Type B)
T3	=	Phillips Truss Head Tapping Screw (Correspond to Type C)
FT	=	Phillips Truss Head Tapping Screw (Special)
BH	=	Hexagon Head Bolt
BC	=	Socket Head Cap Screw
BS	=	Hexagon Bolt with Split Washer
BW	=	Hexagon Bolt with Split Washer and Flat Washer
BF	=	Hexagon Flange Bolt
BR	=	Cross-Recessed Hexagon Head Bolt
BRW	=	Cross-Recessed Hexagon Head Bolt with Split Lock Washer and Flat Washer
WL	=	Split Lock Washer
WT	=	External Tooth Washer
WF	=	Flat Washer
WS	=	Spring Washer
NH	=	Hexagon Nut
NF	=	Hexagon Flange Nut
NC	=	Hexagon Cap Nut
NS	=	Square Nut
NW	=	Wing Nut

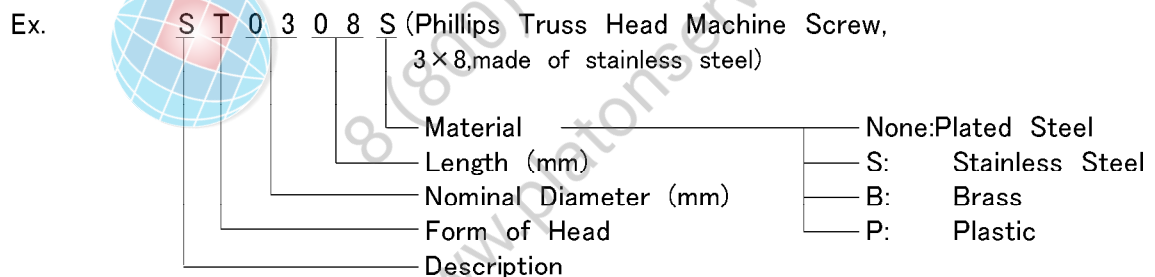

(Note) Second character is numerical except the list.  
Ex: S1,S2,B3 etc.

And abbreviations and names are shown under the illustration.



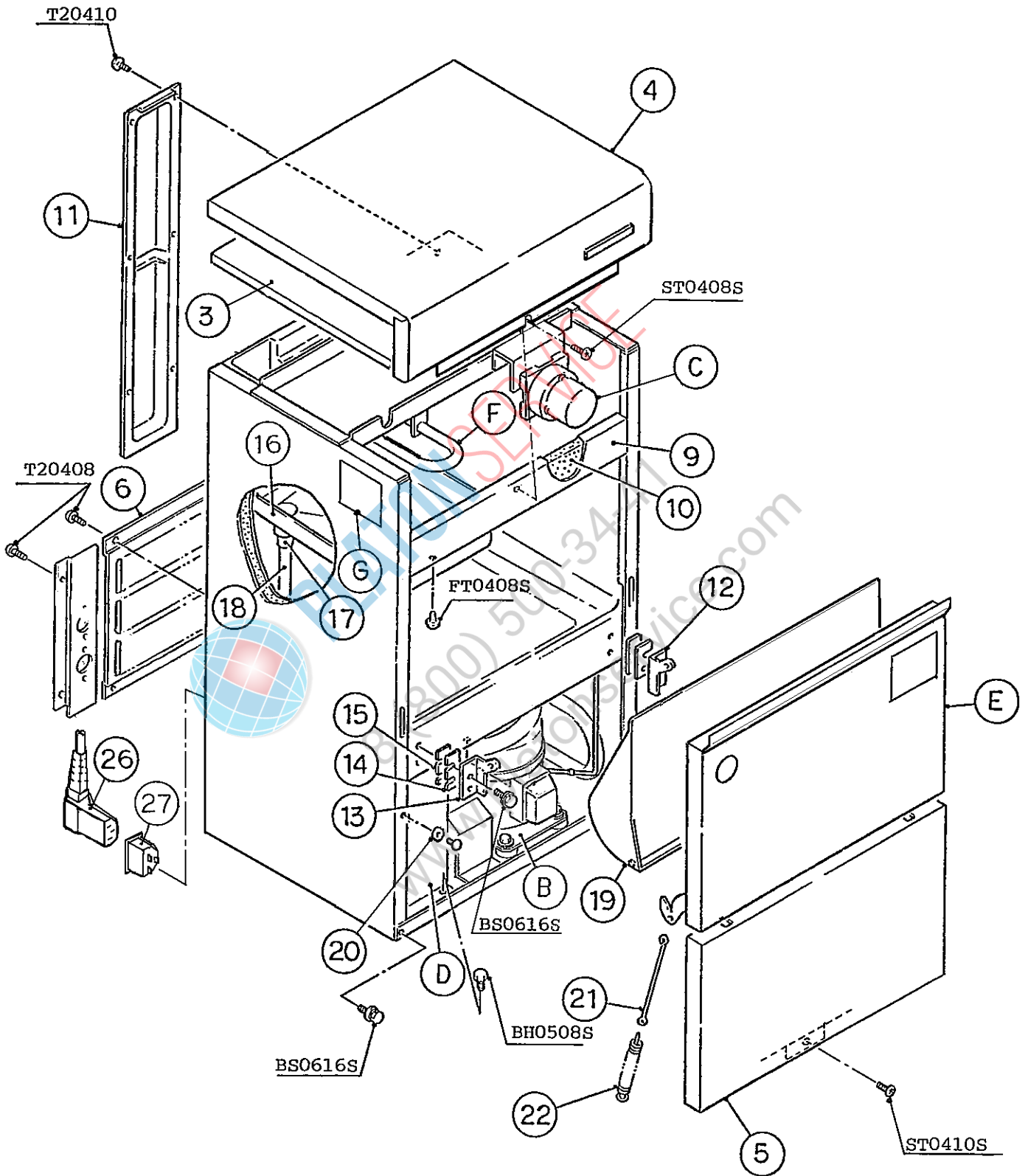

**HE, GENERAL, EXPORT, KOREA, RINNAI, OCEANIA**

MODEL : <b>IM-65WLE, IM-65WLE-25</b> TITLE : <b>A. ICE CUBER ASSY</b>							
INDEX NO.	DESCRIPTION	MATERIAL OR MODEL NUMBER	PART NUMBER	REQ'D NUMBER			
				G-1 H-0	H-1 J-0 K-0	K-1 A-0	B-1 C-0
B	REFRIGERATION ASSY	-	1H1574A01	1	1	-	
		-	1H2144A01			1	-
		-	1H2525A01				1
		-	1H3341A01				
C	ICE MAKING MECHANISM ASSY	(IM-65WLE)	1H0253A10	1	1	1	1
	ICE MAKING MECHANISM ASSY	(IM-65WLE-25)	-	1	1	1	1
D	CONTROL BOX ASSY	-	2H3211A02	1	-		
		-	2H3211A04		1	-	
		-	2H3211A05			1	1
E	DOOR ASSY	-	3H0284A07	1	1	1	1
		-	3Y2748A01				
		-	3Y2903A01				
F	WATER CIRCUIT ASSY	-	3H9589A01	1	1	1	1
G	LABEL LOCATION	(IM-65WLE)	3X0028A01	1	-		
			3X0028A02		1	1	-
			3X0028A03				1
			3X0028A04				
	LABEL LOCATION	(IM-65WLE-25)	-	1	1	1	1
1	UNIT FRAME	PAINTED STEEL	1H0255G12	1	1	1	1
		PAINTED STEEL	1H2948G02				
		PAINTED STEEL	1H2948G06				
2	TOP PANEL	S.S	3H9606-03	1	1	1	1
3	INSULATION - TOP PANEL	PS	2H0655-04	1	1	1	1
4	FRONT PANEL (UPPER)	S.S	3H8109G03	1	1	1	1
	FRONT PANEL (UPPER)	S.S	3X7334G03				
	FRONT PANEL (UPPER)	(RINNAI)	3H8109G07	1	1	1	1
5	FRONT PANEL (LOWER)	S.S	3X0060-01	1	1	1	1
6	REAR PANEL	G.S	3X0027-01	1	1	1	1
7	LOUVER	ABS	101812-09	2	2	×	
8	COVER	G.S	4H6397G01	1	1	×	
9	FRONT FRAME	S.S	3H1678-12	1	1	1	1
10	INSULATION - FRONT FRAME	PE	4H2317-03	1	1	1	1
11	PIPE COVER	G.S	3H0202-03	1	1	1	1
12	HINGE (RIGHT)	S.S	4H2583-01	1	1	1	1

**HE, GENERAL, EXPORT, KOREA, RINNAI, OCEANIA**

MODEL : <b>IM-65WLE, IM-65WLE-25</b> TITLE : <b>A. ICE CUBER ASSY</b>							
INDEX NO.	DESCRIPTION	MATERIAL OR MODEL NUMBER	PART NUMBER	REQ'D NUMBER			
				C-1 D-0	D-1	D-2 E-0	E-1
B	REFRIGERATION ASSY	-	1H1574A01				
		-	1H2144A01				
		-	1H2525A01	1	1	1	1
		-	1H3341A01				
C	ICE MAKING MECHANISM ASSY	(IM-65WLE)	1H0253A10	1	1	1	1
	ICE MAKING MECHANISM ASSY	(IM-65WLE-25)	-	1	1	1	1
D	CONTROL BOX ASSY	-	2H3211A07	1	1	-	
		-	2H3211A09			1	-
		-	2H6762A02				1
E	DOOR ASSY	-	3H0284A07	1	1	1	1
		-	3Y2748A01				
		-	3Y2903A01				
F	WATER CIRCUIT ASSY	-	3H9589A01	1	1	1	1
G	LABEL LOCATION	(IM-65WLE)	-				
			-				
		3X0028A03	1	1	1	-	
		3X0028A04				1	
	LABEL LOCATION	(IM-65WLE-25)	-	1	1	1	1
1	UNIT FRAME	PAINTED STEEL	1H0255G12	1	-		
		PAINTED STEEL	1H2948G02		1	1	1
		PAINTED STEEL	1H2948G06				
2	TOP PANEL	S.S	3H9606-03	1	1	1	1
3	INSULATION - TOP PANEL	PS	2H0655-04	1	1	1	1
4	FRONT PANEL (UPPER)	S.S	3H8109G03	1	1	1	1
	FRONT PANEL (UPPER)	S.S	3X7334G03				
	FRONT PANEL (UPPER)	(RINNAI)	3H8109G07	1	1	1	1
5	FRONT PANEL (LOWER)	S.S	3X0060-01	1	1	1	1
6	REAR PANEL	G.S	3X0027-01	1	1	1	1
7	-	-	-				
8	-	-	-				
9	FRONT FRAME	S.S	3H1678-03	1	1	1	1
10	INSULATION - FRONT FRAME	PE	4H2317-03	1	1	1	1
11	PIPE COVER	G.S	3H0202-03	1	1	1	1
12	HINGE (RIGHT)	S.S	4H2583-01	1	1	1	1

**HE, GENERAL, EXPORT, KOREA, RINNAI, OCEANIA**

MODEL : <b>IM-65WLE, IM-65WLE-25</b> TITLE : <b>A. ICE CUBER ASSY</b>							
INDEX NO.	DESCRIPTION	MATERIAL OR MODEL NUMBER	PART NUMBER	REQ'D NUMBER			
				E-2 F-0 G-01	G-11	H-11 T-1,U-0 V-0,L-0	
B	REFRIGERATION ASSY	-	1H1574A01				
		-	1H2144A01				
		-	1H2525A01	-			
		-	1H3341A01	1	1	1	
C	ICE MAKING MECHANISM ASSY	(IM-65WLE)	1H0253A10	1	1	1	
	ICE MAKING MECHANISM ASSY	(IM-65WLE-25)	-	1	1	1	
D	CONTROL BOX ASSY	-	2H3211A07				
		-	2H3211A09	-			
		-	2H6762A02	1	1	1	
E	DOOR ASSY	-	3H0284A07	1	-		
		-	3Y2748A01		1	-	
		-	3Y2903A01			1	
F	WATER CIRCUIT ASSY	-	3H9589A01	1	1	1	
G	LABEL LOCATION	(IM-65WLE)	-				
			-				
			3X0028A03	-			
			3X0028A04	1	1	1	
	LABEL LOCATION	(IM-65WLE-25)	-	1	1	1	
1	UNIT FRAME	-	-				
		PAINTED STEEL	1H2948G02	1	-		
		PAINTED STEEL	1H2948G06		1	1	
2	TOP PANEL	S.S	3H9606-03	1	×		
3	INSULATION - TOP PANEL	PS	2H0655-04	1	1	1	
4	FRONT PANEL (UPPER)	S.S	3H8109G03	1	-		
	FRONT PANEL (UPPER)	S.S	3X7334G03		1	1	
	FRONT PANEL (UPPER)	(RINNAI)	3H8109G07	1	1	1	
5	FRONT PANEL (LOWER)	S.S	3X0060-01	1	1	1	
6	REAR PANEL	G.S	3X0027-01	1	1	1	
7	-	-	-				
8	-	-	-				
9	FRONT FRAME	S.S	3H1678-03	1	1	1	
10	INSULATION - FRONT FRAME	PE	4H2317-03	1	1	1	
11	PIPE COVER	G.S	3H0202-03	1	1	1	
12	HINGE (RIGHT)	S.S	4H2583-01	1	1	1	







**HE, GENERAL, EXPORT, KOREA, RINNAI, OCEANIA**

MODEL : <b>IM-65WLE, IM-65WLE-25</b> TITLE : <b>A. ICE CUBER ASSY</b>							
INDEX NO.	DESCRIPTION	MATERIAL OR MODEL NUMBER	PART NUMBER	REQ'D NUMBER			
				E-2 F-0 G-01	G-11	H-11 T-1,U-0 V-0,L-0	
13	HINGE (LEFT)	S.S	4H2584-01	1	1	1	
14	HINGE SPACER (A)	S.S	4H0605-01	REQ'D	REQ'D	REQ'D	
15	HINGE SPACER (B)	S.S	4H0605-02	REQ'D	REQ'D	REQ'D	
16	DRAIN PAN	ABS	2H1441-02	1	1	1	
17	DRAIN TUBE	SI	4H2585-01	1	1	1	
18	DRAIN PIPE	ABS	4H1141-07	1	1	1	
19	SLOPE	ABS	2H1349-02	1	1	1	
20	TAPER COLLAR	S.S	4H0171-01	4	2	2	
21	HOOK	S.S	404060-10	1	1	1	
22	SPRING	ZINC-PLATED WIRE	4H0823-01	1	1	1	
23	BRACKET - DRAIN	G.S	4X4491-01	1	1	1	
24	POWER SUPPLY CORD (CONTINENTAL)	(HE) (KOREA)	452263-01	1	×		
	POWER SUPPLY CORD (UK)	(HE)	4X3521G01	1	×		
	POWER SUPPLY CORD	(GENERAL) (EXPORT) (OCEANIA) (RINNAI)	458139-01	1	×		
25	CORD BUSHING	CEE SR-6P-10	448949-01	1	×		
26	POWER CORD	(CONTINENTAL)	P00240-01		1	1	
	POWER CORD (WITH UK PLUG)	(UK)	P00241-01		1	1	
	POWER CORD	(AUSTRALIA)	P00242-01		1	1	
27	CONNECTOR	-	P00245-01		1	1	

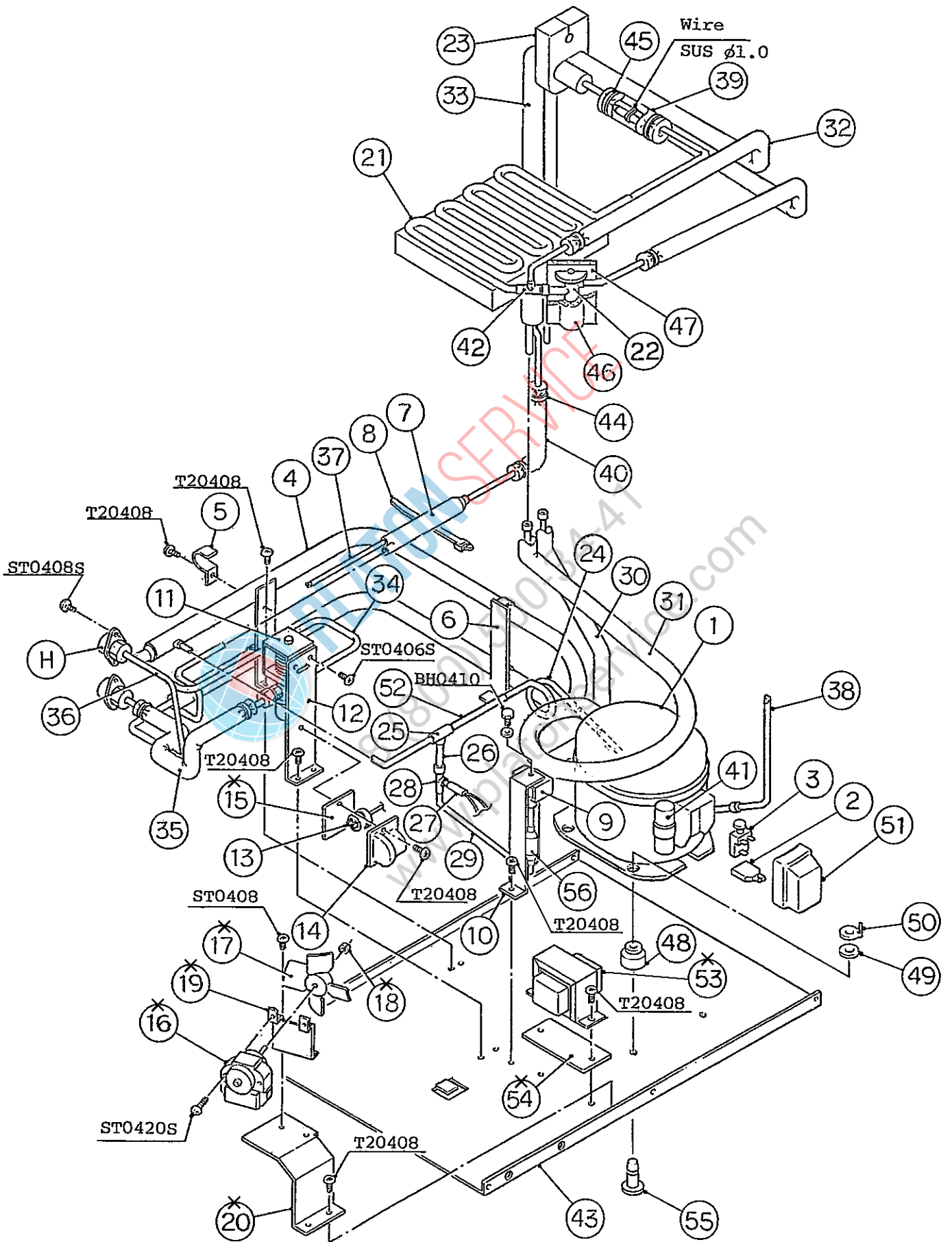

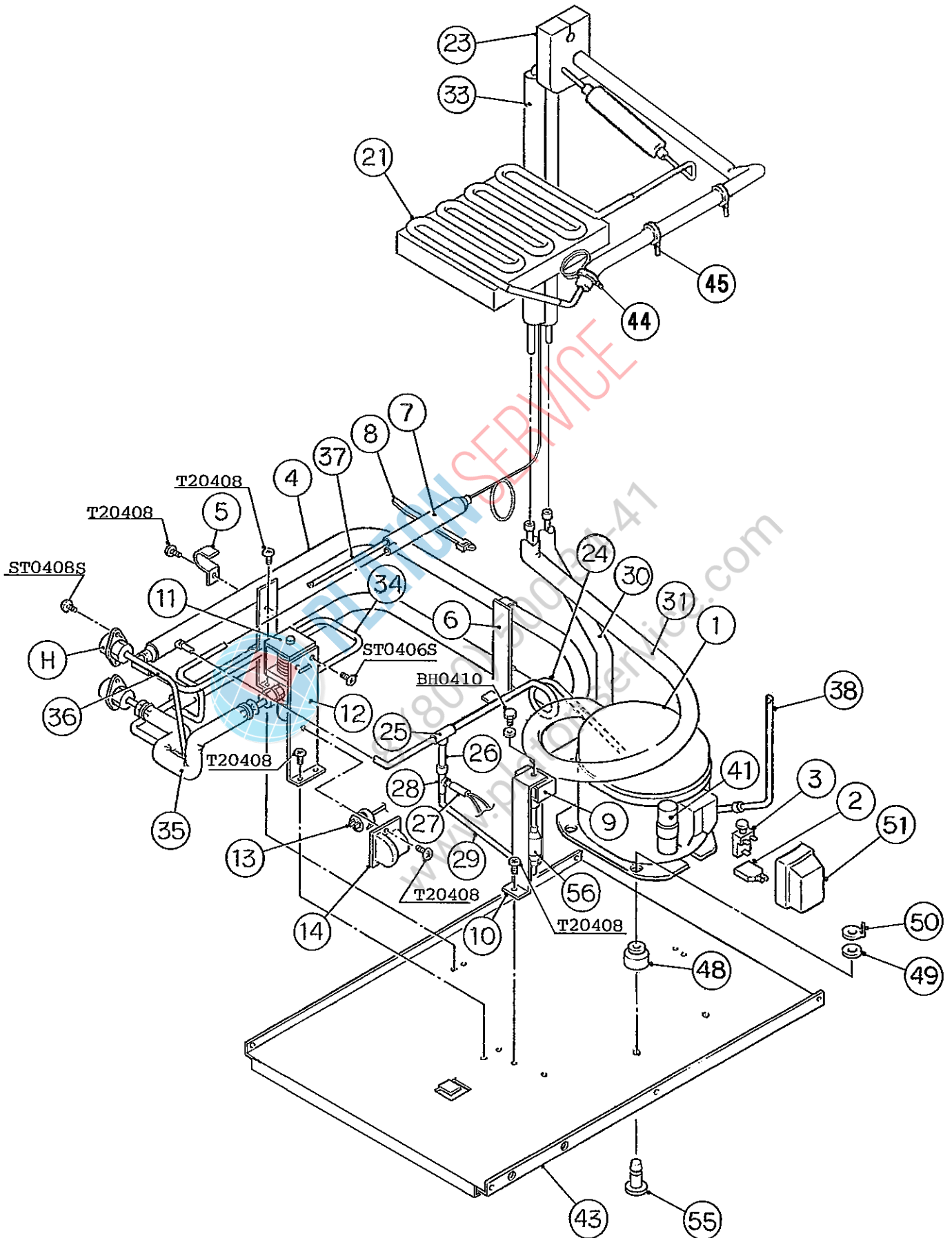

## HE, GENERAL, RINNAI, OCEANIA

MODEL : <b>IM-65WLE, IM-65WLE-25</b> TITLE : <b>B. REFRIGERATION CIRCUIT</b>							
INDEX NO.	DESCRIPTION	MATERIAL OR MODEL NUMBER	PART NUMBER	REQ'D NUMBER			
				G-1 H-0	H-1 J-0 K-0	K-1 A-0	B-1 C-0
H	FITTING (P) ASSY	(S-10101)	3Y0747A01	2	2	2	2
1	COMPRESSOR	FR11G	451196-01	1	1	1	1
2	CORD RELIEF	103N1006	450899-01	1	1	1	1
3	STARTING RELAY	117U6010	451197-01	1	1	1	1
4	CONDENSER	(S-0726)	2H1589G01	1	1	1	—
		(S-9223)	2H3554G01				1
5	CLAMP (B) - CON.	G.S	4H0622-01	4	4	4	4
6	BRACKET - CONDENSER	G.S	4H5731-01	2	2	2	2
7	DRIER	KC-7860	444395-01	1	1	1	—
		DY-15QHD-10	458773-01				1
		DY-12QHD-3	445655-04				
8	TIE	T30RSF	436156-01	1	1	1	1
9	HOT GAS SOLENOID VALVE	AMS-24B10HD-1	418866-02	1	1	1	1
10	BRACKET - HOT GAS VALVE	G.S	4H5186-01	1	1	1	1
11	WATER REGULATOR	WVII 33-MHD-6	448082-01	1	1	1	1
12	BRACKET - WATER REGULATOR	G.S	4X5632-01	1	1	1	1
13	PRESSURE SWITCH	SAP-15-HD	425648-02	1	1	1	1
14	BRACKET - PRESSURE SWITCH	ABS	425506-01	1	1	1	1
15	INSULATION	ABS	4H3046G01	1	1	×	
16	FAN MOTOR	SE14ABF-4	415080-01	1	1	×	
		BJA-7					
17	FAN BLADE	101.5 DIA	414782-01	1	1	×	
18	FAN RING	-	414782F01	1	1	×	
19	BRACKET - FAN MOTOR	S.S	4H5721-01	1	1	×	
20	COVER - TRANSFORMER	G.S	3H9969-01	1	1	×	
21	EVAPORATOR	(IM-65WLE)	3H6803G02	1	1	1	1
	EVAPORATOR	(IM-65WLE-25)	3H4407G01	1	1	1	1
22	EXPANSION VALVE	FSE-3QHD-1	448190-01	1	1	1	×
23	INSULATION (W)	PE	4X5296-01	1	1	1	1
24	COPPER TUBE (A)	COPPER	4X4434-01	1	1	1	—
			3X5801-01				1
25	TEE	-	420041-09	1	1	1	—
			420041-11				1
26	COPPER TUBE (B)	-	4H6477-01	1	1	1	1

## HE, GENERAL, RINNAI, OCEANIA

MODEL : <b>IM-65WLE, IM-65WLE-25</b> TITLE : <b>B. REFRIGERATION CIRCUIT</b>							
INDEX NO.	DESCRIPTION	MATERIAL OR MODEL NUMBER	PART NUMBER	REQ'D NUMBER			
				C-1 D-0	D-1	D-2 E-0	E-1
H	FITTING (P) ASSY	(S-10101)	3Y0747A01	2	2	2	2
1	COMPRESSOR	FR11G	451196-01	1	1	1	1
2	CORD RELIEF	103N1006	450899-01	1	1	1	1
3	STARTING RELAY	117U6010	451197-01	1	1	1	1
4	CONDENSER	-	-				
		(S-9223)	2H3554G01	1	1	1	1
5	CLAMP (B) - CON.	G.S	4H0622-01	4	4	4	4
6	BRACKET - CONDENSER	G.S	4H5731-01	2	2	2	2
7	DRIER	-	-				
		DY-15QHD-10	458773-01	1	1	1	1
		DY-12QHD-3	445655-04				
8	TIE	T30RSF	436156-01	1	1	1	1
9	HOT GAS SOLENOID VALVE	AMS-24B10HD-1	418866-02	1	1	1	1
10	BRACKET - HOT GAS VALVE	G.S	4H5186-01	1	1	1	1
11	WATER REGULATOR	WVII 33-MHD-6	448082-01	1	1	1	1
12	BRACKET - WATER REGULATOR	G.S	4X5632-01	1	1	1	1
13	PRESSURE SWITCH	SAP-15-HD	425648-02	1	1	1	1
14	BRACKET - PRESSURE SWITCH	ABS	425506-01	1	1	1	1
15	-	-	-				
16	-	-	-				
17	-	-	-				
18	-	-	-				
19	-	-	-				
20	-	-	-				
21	EVAPORATOR	(IM-65WLE)	3H6803G02	1	1	1	1
	EVAPORATOR	(IM-65WLE-25)	3H4407G01	1	1	1	1
22	-	-	-				
23	INSULATION (W)	PE	4X5296-01	1	1	1	1
24	COPPER TUBE (A)	COPPER	-				
			3X5801-01	1	1	1	1
25	TEE	-	-				
			420041-11	1	1	1	1
26	COPPER TUBE (B)	-	4H6477-01	1	1	1	1

## HE, GENERAL, RINNAI, OCEANIA

MODEL : <b>IM-65WLE, IM-65WLE-25</b> TITLE : <b>B. REFRIGERATION CIRCUIT</b>							
INDEX NO.	DESCRIPTION	MATERIAL OR MODEL NUMBER	PART NUMBER	REQ'D NUMBER			
				E-2 F-0 G-01	G-11	H-11 T-1,U-0 V-0,L-0	
H	FITTING (P) ASSY	(S-10101)	3Y0747A01	2	2	2	
1	COMPRESSOR	FR11G	451196-01	1	1	1	
2	CORD RELIEF	103N1006	450899-01	1	1	1	
3	STARTING RELAY	117U6010	451197-01	1	1	1	
4	CONDENSER	-	-				
		(S-9223)	2H3554G01	1	1	1	
5	CLAMP (B) - CON.	G.S	4H0622-01	4	4	4	
6	BRACKET - CONDENSER	G.S	4H5731-01	2	2	2	
7	DRIER	-	-				
		DY-15QHD-10	458773-01	-			
		DY-12QHD-3	445655-04	1	1	1	
8	TIE	T30RSF	436156-01	1	1	1	
9	HOT GAS SOLENOID VALVE	AMS-24B10HD-1	418866-02	1	1	1	
10	BRACKET - HOT GAS VALVE	G.S	4H5186-01	1	1	1	
11	WATER REGULATOR	WVII 33-MHD-6	448082-01	1	1	1	
12	BRACKET - WATER REGULATOR	G.S	4X5632-01	1	1	1	
13	PRESSURE SWITCH	SAP-15-HD	425648-02	1	1	1	
14	BRACKET - PRESSURE SWITCH	ABS	425506-01	1	1	1	
15	-	-	-				
16	-	-	-				
17	-	-	-				
18	-	-	-				
19	-	-	-				
20	-	-	-				
21	EVAPORATOR	(IM-65WLE)	3H6803G02	1	1	1	
	EVAPORATOR	(IM-65WLE-25)	3H4407G01	1	1	1	
22	-	-	-				
23	INSULATION (W)	PE	4X5296-01	1	1	1	
24	COPPER TUBE (A)	COPPER	-				
			3X5801-01	1	1	1	
25	TEE	-	-				
			420041-11	1	1	1	
26	COPPER TUBE (B)	-	4H6477-01	1	1	1	



## HE, GENERAL, RINNAI, OCEANIA

MODEL : <b>IM-65WLE, IM-65WLE-25</b> TITLE : <b>B. REFRIGERATION CIRCUIT</b>							
INDEX NO.	DESCRIPTION	MATERIAL OR MODEL NUMBER	PART NUMBER	REQ'D NUMBER			
				G-1 H-0	H-1 J-0 K-0	K-1 A-0	B-1 C-0
27	COPPER TUBE	COPPER	4H4548-02	1	1	1	1
28	TEE	-	420041-03	1	1	1	1
29	COPPER TUBE (C)	COPPER	4X4454-01	1	1	1	1
30	COPPER TUBE (D) - HOT GAS	COPPER	3H4383G01	1	1	1	1
31	COPPER TUBE (E)	COPPER	3X0031G01	1	1	1	1
32	COPPER TUBE (F) - HOT GAS	COPPER	3H4385G02	1	1	1	×
33	HEAT EXCHANGER	-	3H4386G01	1	1	1	-
			3H9448A02				1
34	PIPE (A) - WATER SUPPLY	COPPER	4H6480G01	1	1	1	1
35	PIPE (B) - WATER SUPPLY	COPPER	4H6481G01	1	1	1	1
36	PIPE (C) - WATER SUPPLY	COPPER	4H6482-01	1	1	1	1
37	PROCESS TUBE	COPPER	4H6475-01	1	1	1	1
38	PROCESS TUBE (B)	COPPER	4X3379-01	1	1	1	1
39	INSULATION (A)	25 ID x 35 OD, L=130	4X8643-01	1	1	1	×
40	INSULATION (B)	7762-1020, L=250	1H2144-56	1	1	1	×
41	STARTING CAPACITOR	117U5015	450898-01	1	1	1	1
42	TEE	-	420335-01	1	1	1	×
43	BASE	G.S	3X4390G02	1	1	1	-
			2H5704-02				1
44	TIE	CV-100	7920-0002	REQ'D	REQ'D	REQ'D	REQ'D
45	TIE	CV-150	7920-0003	REQ'D	REQ'D	REQ'D	REQ'D
46	COVER (A) - EXPANSION VALVE	PE	4H9239-01	1	1	1	×
47	COVER (B) - EXPANSION VALVE	PE	4H9239-02	1	1	1	×
48	RUBBER GROMMET	CR-N, NR	450897-01	4	4	4	4
49	WASHER	-	450894-01	4	4	4	4
50	CLIP	-	452256-01	4	4	4	4
51	COVER	103N2010	450896-01	1	1	1	1
52	PIPE / JOINT	COPPER	4X4443-01	1	1	1	×
53	TRANSFORMER	230V / 100V	450104-01	1	1	×	
54	BASE - TRANSFORMER	ABS	4X4432-01	1	1	×	
55	STEEL PIN	-	452255-01	4	4	4	4
56	STRAINER	COPPER	451772-01	1	1	1	1

## HE, GENERAL, RINNAI, OCEANIA

MODEL : <b>IM-65WLE, IM-65WLE-25</b> TITLE : <b>B. REFRIGERATION CIRCUIT</b>							
INDEX NO.	DESCRIPTION	MATERIAL OR MODEL NUMBER	PART NUMBER	REQ'D NUMBER			
				C-1 D-0	D-1	D-2 E-0	E-1
27	COPPER TUBE	COPPER	4H4548-02	1	1	1	1
28	TEE	-	420041-03	1	1	1	1
29	COPPER TUBE (C)	COPPER	4X4454-01	1	1	1	1
30	COPPER TUBE (D) - HOT GAS	COPPER	3H4383G01	1	1	1	1
31	COPPER TUBE (E)	COPPER	3X0031G01	1	1	1	1
32	-	-	-				
33	HEAT EXCHANGER	-	3H9448A02	1	1	1	1
34	PIPE (A) - WATER SUPPLY	COPPER	4H6480G01	1	1	1	1
35	PIPE (B) - WATER SUPPLY	COPPER	4H6481G01	1	1	1	1
36	PIPE (C) - WATER SUPPLY	COPPER	4H6482-01	1	1	1	1
37	PROCESS TUBE	COPPER	4H6475-01	1	1	1	1
38	PROCESS TUBE (B)	COPPER	4X3379-01	1	1	1	1
39	-	-	-				
40	-	-	-				
41	STARTING CAPACITOR	117U5015	450898-01	1	1	1	1
42	-	-	-				
43	BASE	G.S	2H5704-02	1	1	1	1
44	TIE	CV-100	7920-0002	REQ'D	REQ'D	REQ'D	REQ'D
45	TIE	CV-150	7920-0003	REQ'D	REQ'D	REQ'D	REQ'D
46	-	-	-				
47	-	-	-				
48	RUBBER GROMMET	CR-N, NR	450897-01	4	4	4	4
49	WASHER	-	450894-01	4	4	4	4
50	CLIP	-	452256-01	4	4	4	4
51	COVER	103N2010	450896-01	1	1	1	1
52	-	-	-				
53	-	-	-				
54	-	-	-				
55	STEEL PIN	-	452255-01	4	4	4	4
56	STRAINER	COPPER	451772-01	1	1	1	1

**HE, GENERAL, RINNAI, OCEANIA**

MODEL : <b>IM-65WLE, IM-65WLE-25</b> TITLE : <b>B. REFRIGERATION CIRCUIT</b>							
INDEX NO.	DESCRIPTION	MATERIAL OR MODEL NUMBER	PART NUMBER	REQ'D NUMBER			
				E-2 F-0 G-01	G-11	H-11 T-1,U-0 V-0,L-0	
27	COPPER TUBE	COPPER	4H4548-02	1	1	1	
28	TEE	-	420041-03	1	1	1	
29	COPPER TUBE (C)	COPPER	4X4454-01	1	1	1	
30	COPPER TUBE (D) - HOT GAS	COPPER	3H4383G01	1	1	1	
31	COPPER TUBE (E)	COPPER	3X0031G01	1	1	1	
32	-	-	-				
33	HEAT EXCHANGER	-	3H9448A02	1	1	1	
34	PIPE (A) - WATER SUPPLY	COPPER	4H6480G01	1	1	1	
35	PIPE (B) - WATER SUPPLY	COPPER	4H6481G01	1	1	1	
36	PIPE (C) - WATER SUPPLY	COPPER	4H6482-01	1	1	1	
37	PROCESS TUBE	COPPER	4H6475-01	×			
38	PROCESS TUBE (B)	COPPER	4X3379-01	1	1	1	
39	-	-	-				
40	-	-	-				
41	STARTING CAPACITOR	117U5015	450898-01	1	1	1	
42	-	-	-				
43	BASE	G.S	2H5704-02	1	1	1	
44	TIE	CV-100	7920-0002	REQ'D	REQ'D	REQ'D	
45	TIE	CV-150	7920-0003	REQ'D	REQ'D	REQ'D	
46	-	-	-				
47	-	-	-				
48	RUBBER GROMMET	CR-N, NR	450897-01	4	4	4	
49	WASHER	-	450894-01	4	4	4	
50	CLIP	-	452256-01	4	4	4	
51	COVER	103N2010	450896-01	1	1	1	
52	-	-	-				
53	-	-	-				
54	-	-	-				
55	STEEL PIN	-	452255-01	4	4	4	
56	STRAINER	COPPER	451772-01	1	1	1	

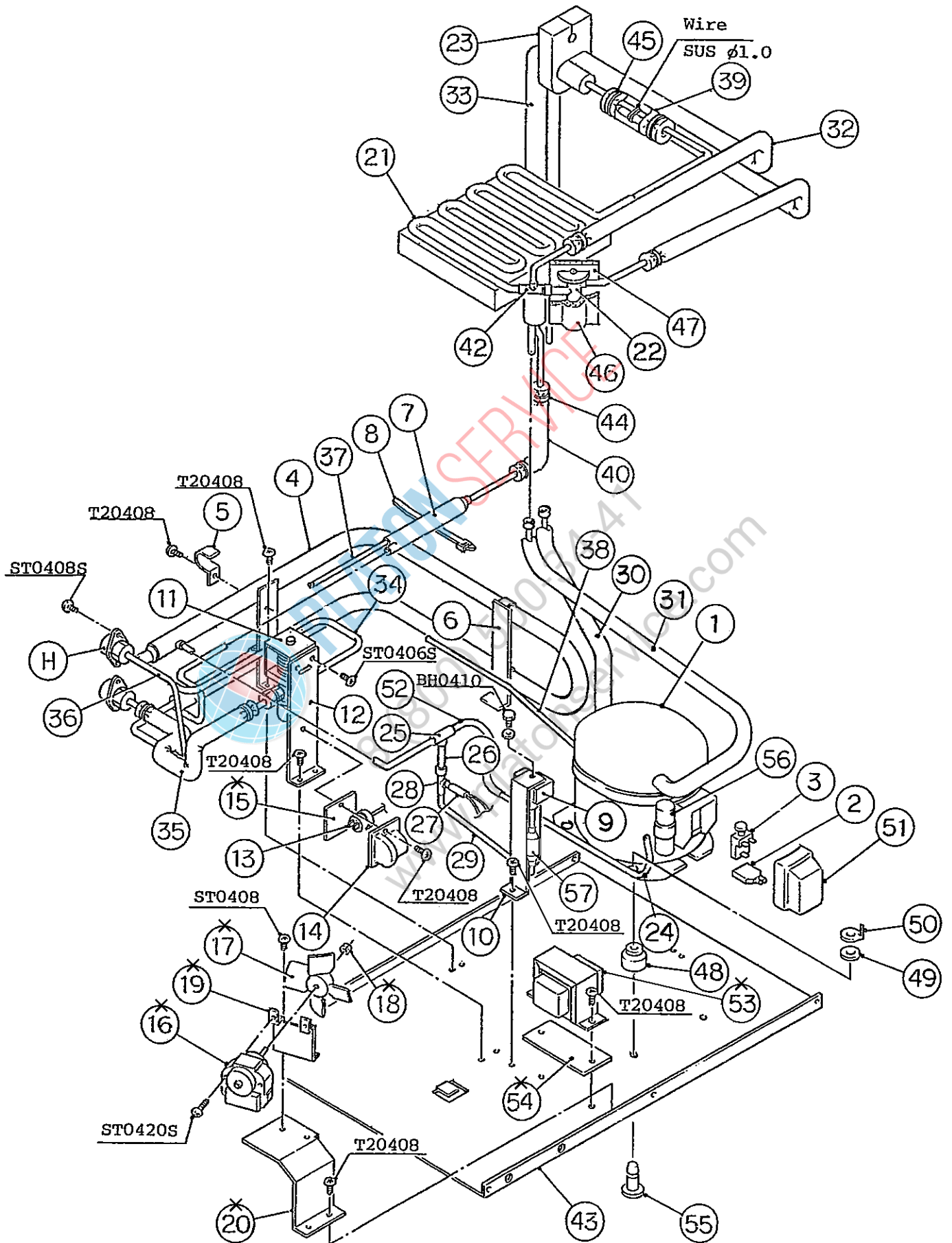

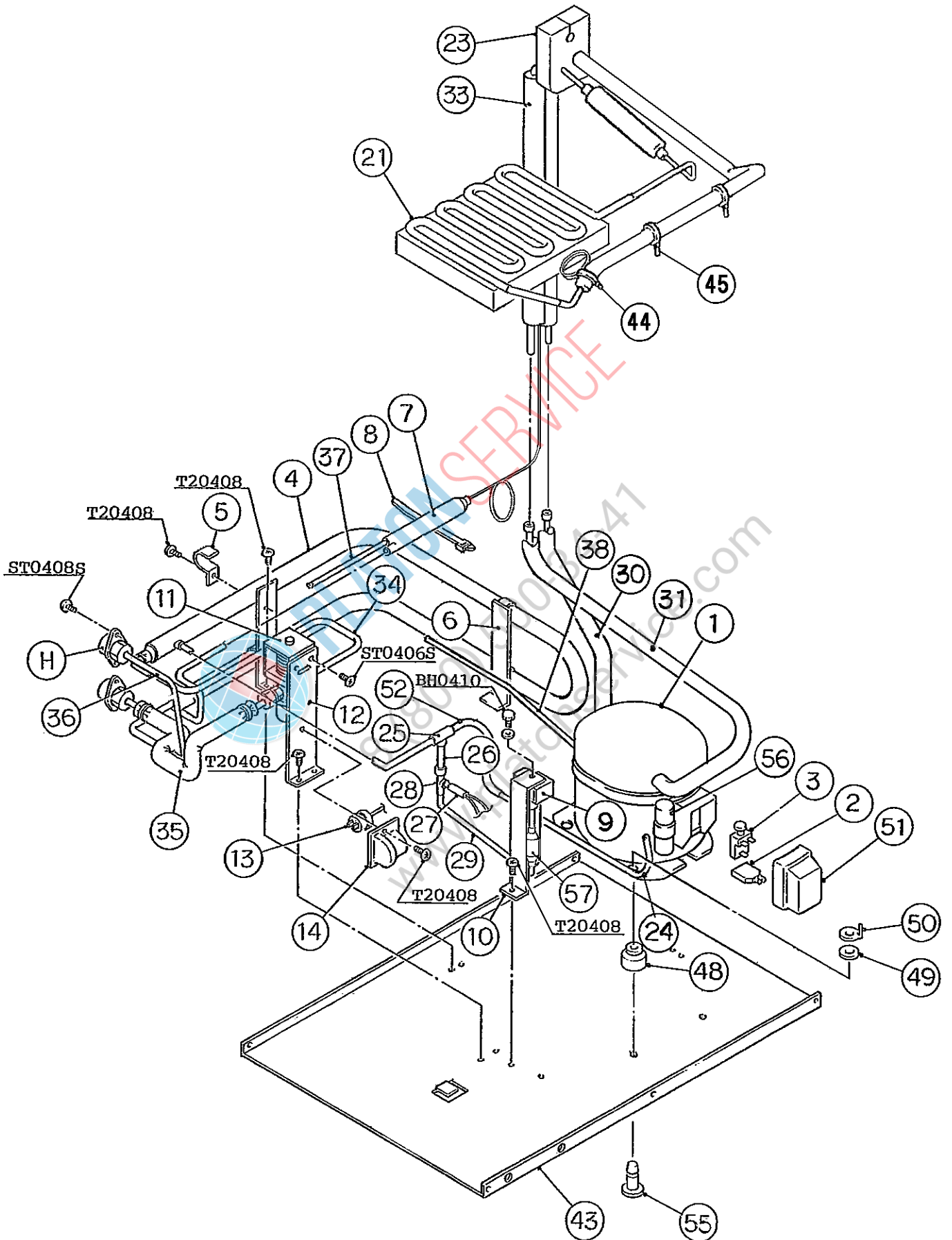

**EXPORT, KOREA**

MODEL : <b>IM-65WLE, IM-65WLE-25</b> TITLE : <b>B. REFRIGERATION CIRCUIT</b>							
INDEX NO.	DESCRIPTION	MATERIAL OR MODEL NUMBER	PART NUMBER	REQ'D NUMBER			
				G-1 H-0	H-1 J-0 K-0	K-1 A-0	B-1 C-0
H	FITTING (P) ASSY	(S-10101)	3Y0747A01	2	2	2	2
1	COMPRESSOR	SC12G	453580-01	1	1	1	1
2	CORD RELIEF	103N1004	452239-01	1	1	1	1
3	STARTING RELAY	117U6003	453581-01	1	1	1	1
4	CONDENSER	(S-0726)	2H1589G01	1	1	1	—
		(S-9223)	2H3554G01				1
5	CLAMP (B) - CON.	G.S	4H0622-01	4	4	4	4
6	BRACKET - CONDENSER	G.S	4H5731-01	2	2	2	2
7	DRIER	KC-7860	444395-01	1	1	1	—
		DY-15QHD-10	458773-01				1
		DY-12QHD-3	445655-04				
8	TIE	T30RSF	436156-01	1	1	1	1
9	HOT GAS SOLENOID VALVE	AMS-24B10HD-1	418866-02	1	1	1	1
10	BRACKET - HOT GAS VALVE	G.S	4H5186-01	1	1	1	1
11	WATER REGULATOR	WVII 33-MHD-6	448082-01	1	1	1	1
12	BRACKET - WATER REGULATOR	G.S	4X5632-01	1	1	1	1
13	PRESSURE SWITCH	SAP-15-HD	425648-02	1	1	1	1
14	BRACKET - PRESSURE SWITCH	ABS	425506-01	1	1	1	1
15	INSULATION	ABS	4H3046G01	1	1	×	
16	FAN MOTOR	SE14ABF-4	415080-01	1	1	×	
		BJA-7					
17	FAN BLADE	101.5 DIA	414782-01	1	1	×	
18	FAN RING	-	414782F01	1	1	×	
19	BRACKET - FAN MOTOR	S.S	4H5721-01	1	1	×	
20	COVER - TRANSFORMER	G.S	3H9969-01	1	1	×	
21	EVAPORATOR	(IM-65WLE)	3H6803G02	1	1	1	1
	EVAPORATOR	(IM-65WLE-25)	3H4407G01	1	1	1	1
22	EXPANSION VALVE	FSE-3QHD-1	448190-01	1	1	1	1
23	INSULATION (W)	PE	4X5296-01	1	1	1	1
24	COPPER TUBE (A)	COPPER	4X5080-01	1	1	1	1
25	TEE	-	420041-09	1	1	1	—
			420041-11				1
26	COPPER TUBE (B)	-	4H6477-01	1	1	1	1
27	COPPER TUBE	COPPER	4H4548-02	1	1	1	1

**EXPORT, KOREA**

MODEL : <b>IM-65WLE, IM-65WLE-25</b> TITLE : <b>B. REFRIGERATION CIRCUIT</b>							
INDEX NO.	DESCRIPTION	MATERIAL OR MODEL NUMBER	PART NUMBER	REQ'D NUMBER			
				C-1 D-0	D-1	D-2 E-0	E-1
H	FITTING (P) ASSY	(S-10101)	3Y0747A01	2	2	2	2
1	COMPRESSOR	SC12G	453580-01	1	1	1	1
2	CORD RELIEF	103N1004	452239-01	1	1	1	1
3	STARTING RELAY	117U6003	453581-01	1	1	1	1
4	CONDENSER	-	-				
		(S-9223)	2H3554G01	1	1	1	1
5	CLAMP (B) - CON.	G.S	4H0622-01	4	4	4	4
6	BRACKET - CONDENSER	G.S	4H5731-01	2	2	2	2
7	DRIER	-	-				
		DY-15QHD-10	458773-01	1	1	1	1
		DY-12QHD-3	445655-04				
8	TIE	T30RSF	436156-01	1	1	1	1
9	HOT GAS SOLENOID VALVE	AMS-24B10HD-1	418866-02	1	1	1	1
10	BRACKET - HOT GAS VALVE	G.S	4H5186-01	1	1	1	1
11	WATER REGULATOR	WVII 33-MHD-6	448082-01	1	1	1	1
12	BRACKET - WATER REGULATOR	G.S	4X5632-01	1	1	1	1
13	PRESSURE SWITCH	SAP-15-HD	425648-02	1	1	1	1
14	BRACKET - PRESSURE SWITCH	ABS	425506-01	1	1	1	1
15	-	-	-				
16	-	-	-				
17	-	-	-				
18	-	-	-				
19	-	-	-				
20	-	-	-				
21	EVAPORATOR	(IM-65WLE)	3H6803G02	1	1	1	1
	EVAPORATOR	(IM-65WLE-25)	3H4407G01	1	1	1	1
22	EXPANSION VALVE	FSE-3QHD-1	448190-01	1	1	1	1
23	INSULATION (W)	PE	4X5296-01	1	1	1	1
24	COPPER TUBE (A)	COPPER	4X5080-01	1	1	1	1
25	TEE	-	-				
			420041-11	1	1	1	1
26	COPPER TUBE (B)	-	4H6477-01	1	1	1	1
27	COPPER TUBE	COPPER	4H4548-02	1	1	1	1

**EXPORT, KOREA**

MODEL : <b>IM-65WLE, IM-65WLE-25</b> TITLE : <b>B. REFRIGERATION CIRCUIT</b>							
INDEX NO.	DESCRIPTION	MATERIAL OR MODEL NUMBER	PART NUMBER	REQ'D NUMBER			
				E-2 F-0 G-01	G-11	H-11 T-1,U-0 V-0,L-0	
H	FITTING (P) ASSY	(S-10101)	3Y0747A01	2	2	2	
1	COMPRESSOR	SC12G	453580-01	1	1	1	
2	CORD RELIEF	103N1004	452239-01	1	1	1	
3	STARTING RELAY	117U6003	453581-01	1	1	1	
4	CONDENSER	-	-				
		(S-9223)	2H3554G01	1	1	1	
5	CLAMP (B) - CON.	G.S	4H0622-01	4	4	4	
6	BRACKET - CONDENSER	G.S	4H5731-01	2	2	2	
7	DRIER	-	-				
		DY-15QHD-10	458773-01	-			
		DY-12QHD-3	445655-04	1	1	1	
8	TIE	T30RSF	436156-01	1	1	1	
9	HOT GAS SOLENOID VALVE	AMS-24B10HD-1	418866-02	1	1	1	
10	BRACKET - HOT GAS VALVE	G.S	4H5186-01	1	1	1	
11	WATER REGULATOR	WVII 33-MHD-6	448082-01	1	1	1	
12	BRACKET - WATER REGULATOR	G.S	4X5632-01	1	1	1	
13	PRESSURE SWITCH	SAP-15-HD	425648-02	1	1	1	
14	BRACKET - PRESSURE SWITCH	ABS	425506-01	1	1	1	
15	-	-	-				
16	-	-	-				
17	-	-	-				
18	-	-	-				
19	-	-	-				
20	-	-	-				
21	EVAPORATOR	(IM-65WLE)	3H6803G02	1	1	1	
	EVAPORATOR	(IM-65WLE-25)	3H4407G01	1	1	1	
22	EXPANSION VALVE	FSE-3QHD-1	448190-01	1	1	1	
23	INSULATION (W)	PE	4X5296-01	1	1	1	
24	COPPER TUBE (A)	COPPER	4X5080-01	1	1	1	
25	TEE	-	-				
			420041-11	1	1	1	
26	COPPER TUBE (B)	-	4H6477-01	1	1	1	
27	COPPER TUBE	COPPER	4H4548-02	1	1	1	



**EXPORT, KOREA**

MODEL : <b>IM-65WLE, IM-65WLE-25</b> TITLE : <b>B. REFRIGERATION CIRCUIT</b>							
INDEX NO.	DESCRIPTION	MATERIAL OR MODEL NUMBER	PART NUMBER	REQ'D NUMBER			
				G-1 H-0	H-1 J-0 K-0	K-1 A-0	B-1 C-0
28	TEE	-	420041-03	1	1	1	1
29	COPPER TUBE (C)	COPPER	4X4454-01	1	1	1	1
30	COPPER TUBE (D) - HOT GAS	COPPER	3H4383G01	1	1	1	1
31	COPPER TUBE (E)	COPPER	3X1131G01	1	1	1	1
32	COPPER TUBE (F) - HOT GAS	COPPER	3H4385G02	1	1	1	1
33	HEAT EXCHANGER	-	3H4386G01	1	1	1	1
34	PIPE (A) - WATER SUPPLY	COPPER	4H6480G01	1	1	1	1
35	PIPE (B) - WATER SUPPLY	COPPER	4H6481G01	1	1	1	1
36	PIPE (C) - WATER SUPPLY	COPPER	4H6482-01	1	1	1	1
37	PROCESS TUBE	COPPER	4H6475-01	1	1	1	1
38	PROCESS TUBE (B)	COPPER	4X4459-01	1	1	1	1
39	INSULATION (A)	25 ID x 35 OD, L=130	4X8643-01	1	1	1	1
40	INSULATION (B)	7762-1020, L=250	1H2144-56	1	1	1	1
41	-	-	-				
42	TEE	-	420335-01	1	1	1	1
43	BASE	G.S	3X4390G02	1	1	1	1
44	TIE	CV-100	7920-0002	REQ'D	REQ'D	REQ'D	REQ'D
45	TIE	CV-150	7920-0003	REQ'D	REQ'D	REQ'D	REQ'D
46	COVER (A) - EXPANSION VALVE	PE	4H9239-01	1	1	1	1
47	COVER (B) - EXPANSION VALVE	PE	4H9239-02	1	1	1	1
48	RUBBER GROMMET	CR-N, NR	450897-01	4	4	4	4
49	WASHER	-	450894-01	4	4	4	4
50	CLIP	-	452256-01	4	4	4	4
51	COVER	103N2009	459924-01	1	1	1	1
52	PIPE / CUSHION	COPPER	4X5188-01	1	1	1	-
			4X9562-01				1
53	TRANSFORMER	230V / 100V	450104-01	1	1	×	
54	BASE - TRANSFORMER	ABS	4X4432-01	1	1	×	
55	STEEL PIN	-	452255-01	4	4	4	4
56	STARTING CAPACITOR	117U5019	456350-01	1	1	1	1
57	STRAINER	COPPER	451772-01	1	1	1	1

**EXPORT, KOREA**

MODEL : <b>IM-65WLE, IM-65WLE-25</b> TITLE : <b>B. REFRIGERATION CIRCUIT</b>							
INDEX NO.	DESCRIPTION	MATERIAL OR MODEL NUMBER	PART NUMBER	REQ'D NUMBER			
				C-1 D-0	D-1	D-2 E-0	E-1
28	TEE	-	420041-03	1	1	1	1
29	COPPER TUBE (C)	COPPER	4X4454-01	1	1	1	1
30	COPPER TUBE (D) - HOT GAS	COPPER	3H4383G01	1	1	1	1
31	COPPER TUBE (E)	COPPER	3X1131G01	1	1	1	1
32	COPPER TUBE (F) - HOT GAS	COPPER	3H4385G02	1	1	1	1
33	HEAT EXCHANGER	-	3H4386G01	1	1	1	1
34	PIPE (A) - WATER SUPPLY	COPPER	4H6480G01	1	1	1	1
35	PIPE (B) - WATER SUPPLY	COPPER	4H6481G01	1	1	1	1
36	PIPE (C) - WATER SUPPLY	COPPER	4H6482-01	1	1	1	1
37	PROCESS TUBE	COPPER	4H6475-01	1	1	1	1
38	PROCESS TUBE (B)	COPPER	4X4459-01	1	1	1	1
39	INSULATION (A)	25 ID x 35 OD, L=130	4X8643-01	1	1	1	1
40	INSULATION (B)	7762-1020, L=250	1H2144-56	1	1	1	1
41	-	-	-				
42	TEE	-	420335-01	1	1	1	1
43	BASE	G.S	3X4390G02	1	1	1	1
44	TIE	CV-100	7920-0002	REQ'D	REQ'D	REQ'D	REQ'D
45	TIE	CV-150	7920-0003	REQ'D	REQ'D	REQ'D	REQ'D
46	COVER (A) - EXPANSION VALVE	PE	4H9239-01	1	1	1	1
47	COVER (B) - EXPANSION VALVE	PE	4H9239-02	1	1	1	1
48	RUBBER GROMMET	CR-N, NR	450897-01	4	4	4	4
49	WASHER	-	450894-01	4	4	4	4
50	CLIP	-	452256-01	4	4	4	4
51	COVER	103N2009	459924-01	1	1	1	1
52	PIPE / CUSHION	COPPER	-				
			4X9562-01	1	1	1	1
53	-	-	-				
54	-	-	-				
55	STEEL PIN	-	452255-01	4	4	4	4
56	STARTING CAPACITOR	117U5019	456350-01	1	1	1	1
57	STRAINER	COPPER	451772-01	1	1	1	1

**EXPORT, KOREA**

MODEL : <b>IM-65WLE, IM-65WLE-25</b> TITLE : <b>B. REFRIGERATION CIRCUIT</b>							
INDEX NO.	DESCRIPTION	MATERIAL OR MODEL NUMBER	PART NUMBER	REQ'D NUMBER			
				E-2 F-0 G-01	G-11	H-11 T-1,U-0 V-0,L-0	
28	TEE	-	420041-03	1	1	1	
29	COPPER TUBE (C)	COPPER	4X4454-01	1	1	1	
30	COPPER TUBE (D) - HOT GAS	COPPER	3H4383G01	1	1	1	
31	COPPER TUBE (E)	COPPER	3X1131G01	1	1	1	
32	COPPER TUBE (F) - HOT GAS	COPPER	3H4385G02	1	1	1	
33	HEAT EXCHANGER	-	3H4386G01	1	1	1	
34	PIPE (A) - WATER SUPPLY	COPPER	4H6480G01	1	1	1	
35	PIPE (B) - WATER SUPPLY	COPPER	4H6481G01	1	1	1	
36	PIPE (C) - WATER SUPPLY	COPPER	4H6482-01	1	1	1	
37	PROCESS TUBE	COPPER	4H6475-01	×			
38	PROCESS TUBE (B)	COPPER	4X4459-01	1	1	1	
39	INSULATION (A)	25 ID x 35 OD, L=130	4X8643-01	1	1	1	
40	INSULATION (B)	7762-1020, L=250	1H2144-56	1	1	1	
41	-	-	-				
42	TEE	-	420335-01	1	1	1	
43	BASE	G.S	3X4390G02	1	1	1	
44	TIE	CV-100	7920-0002	REQ'D	REQ'D	REQ'D	
45	TIE	CV-150	7920-0003	REQ'D	REQ'D	REQ'D	
46	COVER (A) - EXPANSION VALVE	PE	4H9239-01	1	1	1	
47	COVER (B) - EXPANSION VALVE	PE	4H9239-02	1	1	1	
48	RUBBER GROMMET	CR-N, NR	450897-01	4	4	4	
49	WASHER	-	450894-01	4	4	4	
50	CLIP	-	452256-01	4	4	4	
51	COVER	103N2009	459924-01	1	1	1	
52	PIPE / CUSHION	COPPER	-				
			4X9562-01	1	1	1	
53	-	-	-				
54	-	-	-				
55	STEEL PIN	-	452255-01	4	4	4	
56	STARTING CAPACITOR	117U5019	456350-01	1	1	1	
57	STRAINER	COPPER	451772-01	1	1	1	



**HE, GENERAL, EXPORT, KOREA, RINNAI, OCEANIA**

MODEL : IM-65WLE, IM-65WLE-25 TITLE : C. ICE MAKING MECHANISM ASSY							
INDEX NO.	DESCRIPTION	MATERIAL OR MODEL NUMBER	PART NUMBER	REQ'D NUMBER			
				G-1 H-0	H-1 J-0 K-0	K-1 A-0	B-1 C-0
J	BIN CONTROL SWITCH ASSY	(S-0817)	3H1537A02	1	1	1	1
K	WATER PAN ASSY	(IM-65WLE)	2H0658A04	1	1	1	1
	WATER PAN ASSY	(IM-65WLE-25)	2H0658A05				
	WATER PAN ASSY	(IM-65WLE-25)	-	1	1	1	1
1	ACTUATOR MOTOR	SR65A41-13	452499-01	1	1	1	1
2	BRACKET - ACTUATOR MOTOR	G.S	3H1388-01	1	1	1	1
3	CAM (A)	AC	2H0659-01	1	1	1	1
4	CAM (B)	AC	3H1389-01	1	1	1	1
5	GUIDE - CONNECTOR	-	4H5618-02	1	1	1	1
6	BOARD SUPPORT	KGLS-4S	414929-02	3	3	3	3
7	TIE	CV-100	7920-0002	2	2	2	2
8	HOLDER	575	428644-02	1	1	1	1
9	CAM SHAFT	S.S	4H2589G01	1	1	1	1
10	SPLIT PIN	S.S, 2x12	711S-0212	1	1	1	1
11	SPRING	S.S	4H2590-01	2	2	2	2
12	TOGGLE SWITCH	VAT4-71	431977-01	1	1	1	1
13	WASHER - TOGGLE SWITCH	S.S	406196-01	1	1	1	1
14	SWITCH COVER	PE	408163-01	1	1	1	1
15	CAM SHAFT HOLDER	ABS	307256-01	1	1	1	1
16	BEARING(FRONT) - WATER PAN	S.S	4H2591G02	1	1	1	1
17	BEARING(REAR) - WATER PAN	S.S	4H2592G02	1	1	1	1
18	SCREW - EVAPORATOR MOUNTING	(IM-65WLE)	4H2593-01	4	4	4	4
	SCREW EVAPORATOR	(IM-65WLE-25)	4Y4922M02	4	4	4	4
19	WASHER	AC	4H0777-01	4	4	4	4
20	SPACER	(IM-65WLE)	4H0471-01	4	4	4	4
	SPACER	(IM-65WLE-25)	4X5342-01	4	4	4	4
21	CLAMP	No. 2674	427902-02	1	1	1	1
22	SPRING PIN	S.S, 3x22	712S-0322	1	1	1	1
23	BRACKET - ICE MAKING MECHANISM	(IM-65WLE) PAINTED STEEL	3H9593-01	1	1	1	1
	BRACKET - ICE MAKING MECHANISM	(IM-65WLE-25) PAINTED STEEL	3H9651-01	1	1	1	1

**HE, GENERAL, EXPORT, KOREA, RINNAI, OCEANIA**

MODEL : IM-65WLE, IM-65WLE-25 TITLE : C. ICE MAKING MECHANISM ASSY							
INDEX NO.	DESCRIPTION	MATERIAL OR MODEL NUMBER	PART NUMBER	REQ'D NUMBER			
				C-1 D-0	D-1	D-2 E-0	E-1
J	BIN CONTROL SWITCH ASSY	(S-0817)	3H1537A02	1	1	1	1
K	WATER PAN ASSY	(IM-65WLE)	2H0658A04	—			
	WATER PAN ASSY	(IM-65WLE-25)	2H0658A05	1	1	1	1
	WATER PAN ASSY	(IM-65WLE-25)	-	1	1	1	1
1	ACTUATOR MOTOR	SR65A41-13	452499-01	1	1	1	1
2	BRACKET - ACTUATOR MOTOR	G.S	3H1388-01	1	1	1	1
3	CAM (A)	AC	2H0659-01	1	1	1	1
4	CAM (B)	AC	3H1389-01	1	1	1	1
5	GUIDE - CONNECTOR	-	4H5618-02	1	1	1	1
6	BOARD SUPPORT	KGLS-4S	414929-02	3	3	3	3
7	TIE	CV-100	7920-0002	2	2	2	2
8	HOLDER	575	428644-02	1	1	1	1
9	CAM SHAFT	S.S	4H2589G01	1	1	1	1
10	SPLIT PIN	S.S, 2x12	711S-0212	1	1	1	1
11	SPRING	S.S	4H2590-01	2	2	2	2
12	TOGGLE SWITCH	VAT4-71	431977-01	1	1	1	1
13	WASHER - TOGGLE SWITCH	S.S	406196-01	1	1	1	1
14	SWITCH COVER	PE	408163-01	1	1	1	1
15	CAM SHAFT HOLDER	ABS	307256-01	1	1	1	1
16	BEARING(FRONT) - WATER PAN	S.S	4H2591G02	1	1	1	1
17	BEARING(REAR) - WATER PAN	S.S	4H2592G02	1	1	1	1
18	SCREW - EVAPORATOR MOUNTING	(IM-65WLE)	4H2593-01	4	4	4	4
	SCREW EVAPORATOR	(IM-65WLE-25)	4Y4922M02	4	4	4	4
19	WASHER	AC	4H0777-01	4	4	4	4
20	SPACER	(IM-65WLE)	4H0471-01	4	4	4	4
	SPACER	(IM-65WLE-25)	4X5342-01	4	4	4	4
21	CLAMP	No. 2674	427902-02	1	1	1	1
22	SPRING PIN	S.S, 3x22	712S-0322	1	1	1	1
23	BRACKET - ICE MAKING MECHANISM	(IM-65WLE) PAINTED STEEL	3H9593-01	1	1	1	1
	BRACKET - ICE MAKING MECHANISM	(IM-65WLE-25) PAINTED STEEL	3H9651-01	1	1	1	1
24	-	-	-				
25	HOLDER - THERMISTOR	PE	3H9642-01	1	1	1	1

**HE, GENERAL, EXPORT, KOREA, RINNAI, OCEANIA**

MODEL : IM-65WLE, IM-65WLE-25 TITLE : C. ICE MAKING MECHANISM ASSY							
INDEX NO.	DESCRIPTION	MATERIAL OR MODEL NUMBER	PART NUMBER	REQ'D NUMBER			
				E-2 F-0 G-01	G-11	H-11 T-1,U-0 V-0,L-0	
J	BIN CONTROL SWITCH ASSY	(S-0817)	3H1537A02	1	1	1	
K	WATER PAN ASSY	(IM-65WLE)	2H0658A04				
	WATER PAN ASSY	(IM-65WLE-25)	2H0658A05	1	1	1	
	WATER PAN ASSY	(IM-65WLE-25)	-	1	1	1	
1	ACTUATOR MOTOR	SR65A41-13	452499-01	1	1	1	
2	BRACKET - ACTUATOR MOTOR	G.S	3H1388-01	1	1	1	
3	CAM (A)	AC	2H0659-01	1	1	1	
4	CAM (B)	AC	3H1389-01	1	1	1	
5	GUIDE - CONNECTOR	-	4H5618-02	1	1	1	
6	BOARD SUPPORT	KGLS-4S	414929-02	3	3	3	
7	TIE	CV-100	7920-0002	2	2	2	
8	HOLDER	575	428644-02	1	1	1	
9	CAM SHAFT	S.S	4H2589G01	1	1	1	
10	SPLIT PIN	S.S, 2x12	711S-0212	1	1	1	
11	SPRING	S.S	4H2590-01	2	2	2	
12	TOGGLE SWITCH	VAT4-71	431977-01	1	1	1	
13	WASHER - TOGGLE SWITCH	S.S	406196-01	1	1	1	
14	SWITCH COVER	PE	408163-01	1	1	1	
15	CAM SHAFT HOLDER	ABS	307256-01	1	1	1	
16	BEARING(FRONT) - WATER PAN	S.S	4H2591G02	1	1	1	
17	BEARING(REAR) - WATER PAN	S.S	4H2592G02	1	1	1	
18	SCREW - EVAPORATOR MOUNTING	(IM-65WLE)	4H2593-01	4	4	4	
	SCREW EVAPORATOR	(IM-65WLE-25)	4Y4922M02	4	4	4	
19	WASHER	AC	4H0777-01	4	4	4	
20	SPACER	(IM-65WLE)	4H0471-01	4	4	4	
	SPACER	(IM-65WLE-25)	4X5342-01	4	4	4	
21	CLAMP	No. 2674	427902-02	1	1	1	
22	SPRING PIN	S.S, 3x22	712S-0322	1	1	1	
23	BRACKET - ICE MAKING MECHANISM	(IM-65WLE) PAINTED STEEL	3H9593-01	1	1	1	
	BRACKET - ICE MAKING MECHANISM	(IM-65WLE-25) PAINTED STEEL	3H9651-01	1	1	1	
24	-	-	-				
25	HOLDER - THERMISTOR	PE	3H9642-01	1	1	1	









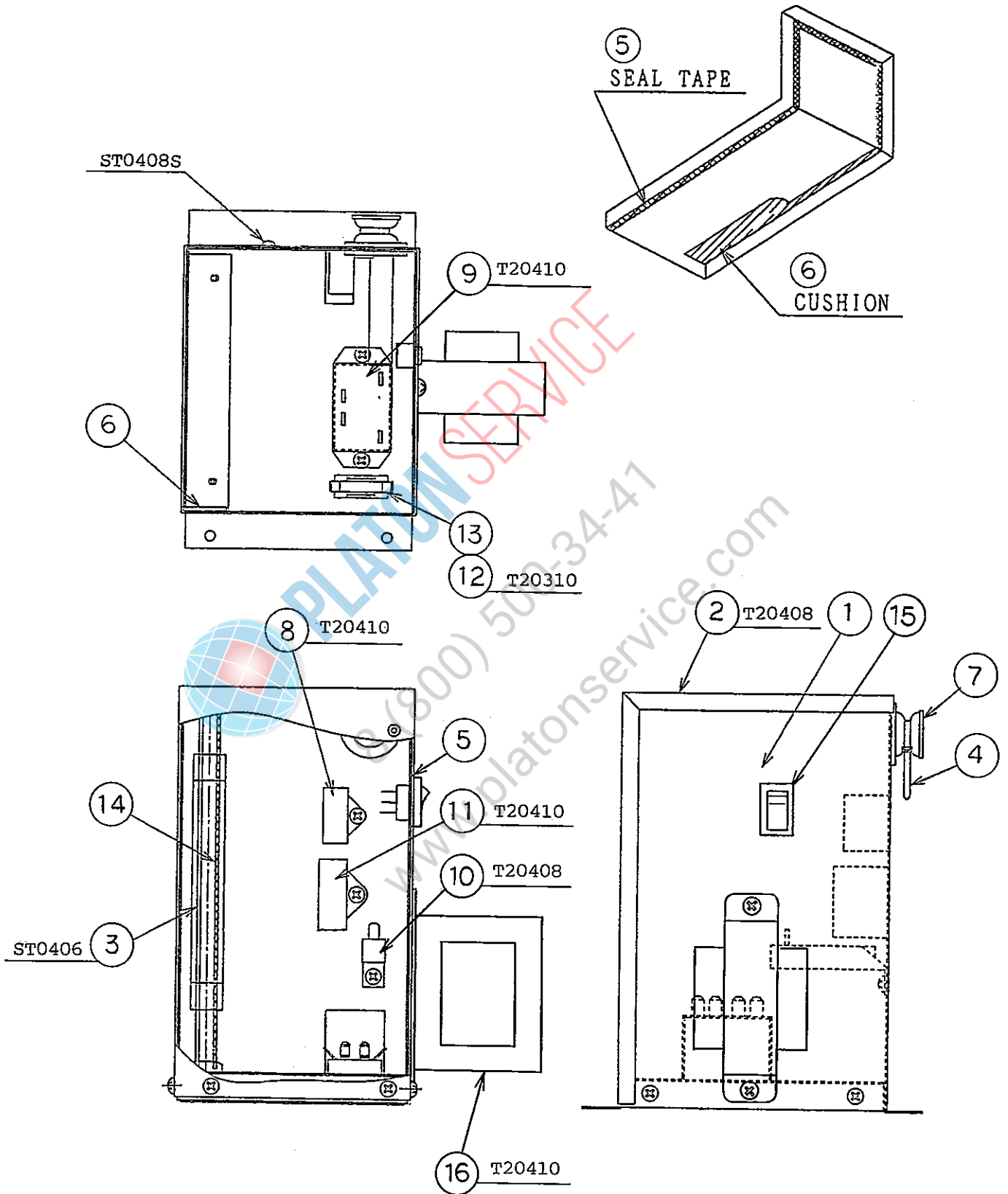

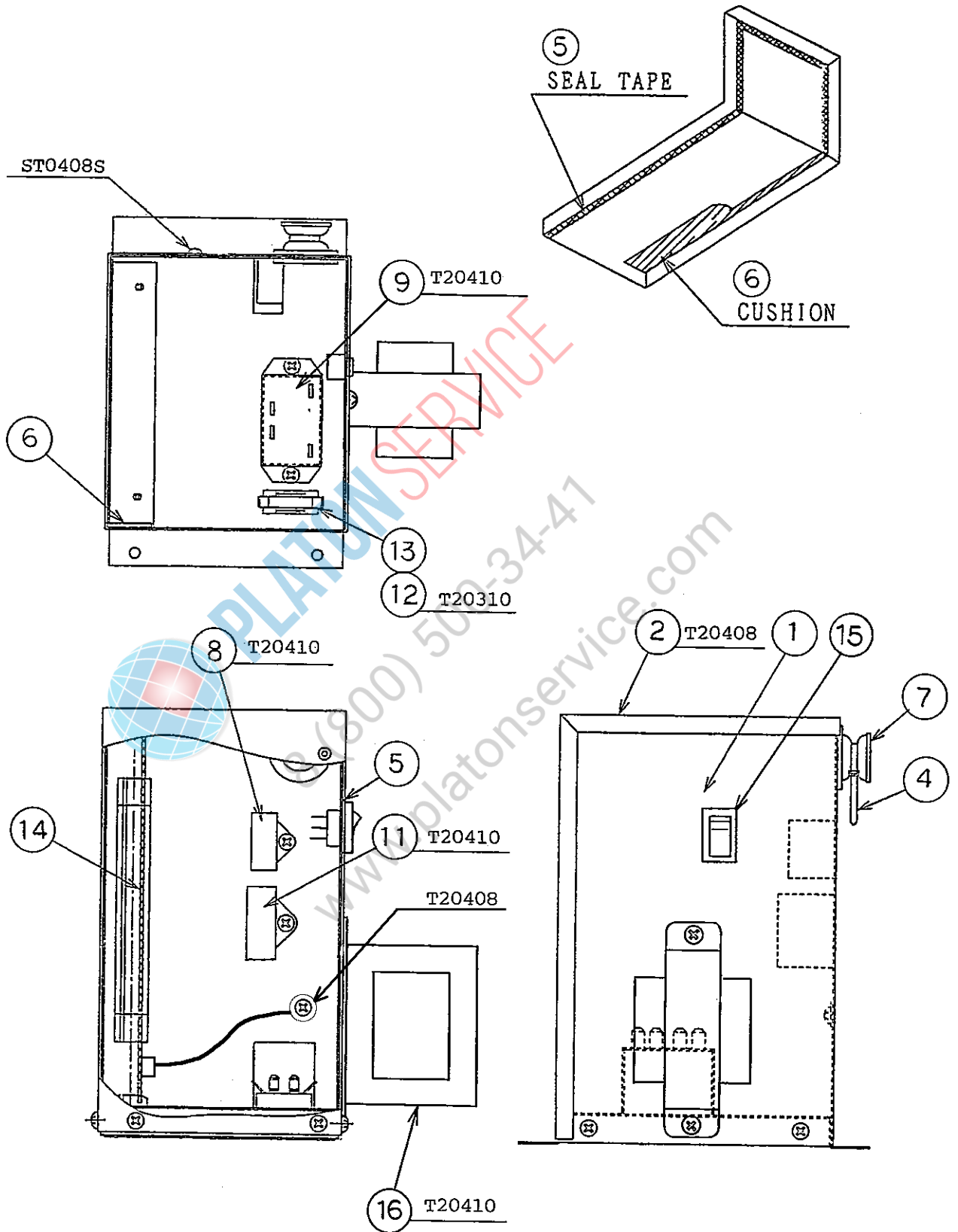

**HE, GENERAL, EXPORT, KOREA, RINNAI, OCEANIA**

MODEL : <b>IM-65WLE, IM-65WLE-25</b> TITLE : <b>D. CONTROL BOX ASSY</b>							
INDEX NO.	DESCRIPTION	MATERIAL OR MODEL NUMBER	PART NUMBER	REQ'D NUMBER			
				G-1 H-0	H-1 J-0 K-0	K-1 A-0	B-1 C-0
1	CONTROL BOX	G.S	3H9453G01	1	—		
		G.S	3H9453G02		1	1	1
2	CONTROL BOX COVER	G.S	3H9456-01	1	1	1	1
3	SHIELD PLATE	G.S	4H2594-01	1	1	1	1
4	NYLON TIE	RT60S	436157-01	1	—		
		PRT1.5S	427466-01		1	1	1
5	SEAL TAPE	w8 x t3.2	2H3211-09	1	1	1	1
		w8 x t3.2	2H6762-06				
6	CUSHION	20 x 210 x 2.5t	4H2718-01	1	1	1	1
7	GROMMET	-	4H2568-01	1	1	1	1
8	CAPACITOR - ACTUATOR MOTOR	0.8μF	456262-01	1	1	1	1
9	POWER RELAY	G7L-1A-TUB	449000-01	1	1	1	1
10	SURGE ABSORBER		436573-02	1	1	1	1
11	CAPACITOR - PUMP MOTOR	4.0UF	416920-02	1	1	1	1
		1.0UF	457885-01				
12	FUSE HOLDER	445710	451925-01	1	1	1	1
		CFH15	4Y2547-01				
13	FUSE	5A	451924-01	1	1	1	1
14	CONTROLLER BOARD	H2AA136C12	436572-12	1	1	1	1
		H2AE024C18	462975-18				
15	ROCKER SWITCH	H8600VB	460681-01		1	1	1
16	TRANSFORMER	230V / 100V	450104-01			1	1

**HE, GENERAL, EXPORT, KOREA, RINNAI, OCEANIA**

MODEL : <b>IM-65WLE, IM-65WLE-25</b> TITLE : <b>D. CONTROL BOX ASSY</b>							
INDEX NO.	DESCRIPTION	MATERIAL OR MODEL NUMBER	PART NUMBER	REQ'D NUMBER			
				C-1 D-0	D-1	D-2 E-0	E-1
1	CONTROL BOX	G.S	3H9453G02	1	1	—	
		G.S	3H9453G04			1	1
2	CONTROL BOX COVER	G.S	3H9456-01	1	1	1	1
3	SHIELD PLATE	G.S	4H2594-01	1	1	1	×
4	NYLON TIE	-	-				
		PRT1.5S	427466-01	1	1	1	1
5	SEAL TAPE	w8 x t3.2	2H3211-09	1	1	1	—
		w8 x t3.2	2H6762-06				1
6	CUSHION	20 x 210 x 2.5t	4H2718-01	1	1	1	1
7	GROMMET	-	4H2568-01	1	1	1	1
8	CAPACITOR - ACTUATOR MOTOR	0.8UF	456262-01	1	1	1	1
9	POWER RELAY	G7L-1A-TUB	449000-01	1	1	1	1
10	SURGE ABSORBER		436573-02	1	1	1	×
11	CAPACITOR - PUMP MOTOR	4.0UF	416920-02	—			
		1.0UF	457885-01	1	1	1	1
12	FUSE HOLDER	445710	451925-01	1	1	—	
		CFH15	4Y2547-01			1	1
13	FUSE	5A	451924-01	1	1	1	1
14	CONTROLLER BOARD	H2AA136C12	436572-12	1	1	1	—
		H2AE024C18	462975-18				1
15	ROCKER SWITCH	H8600VB	460681-01	1	1	1	1
16	TRANSFORMER	230V / 100V	450104-01	1	1	1	1



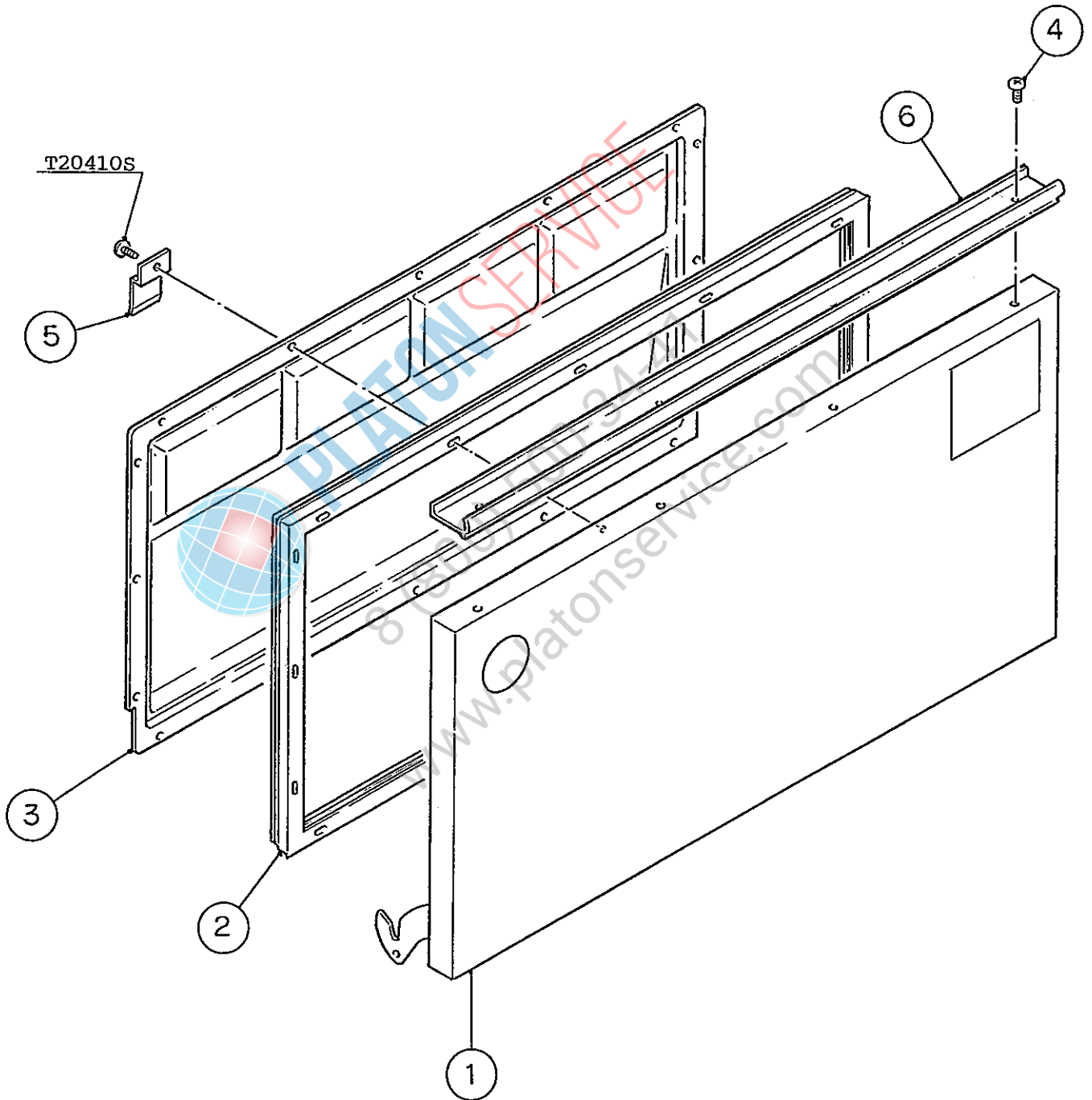



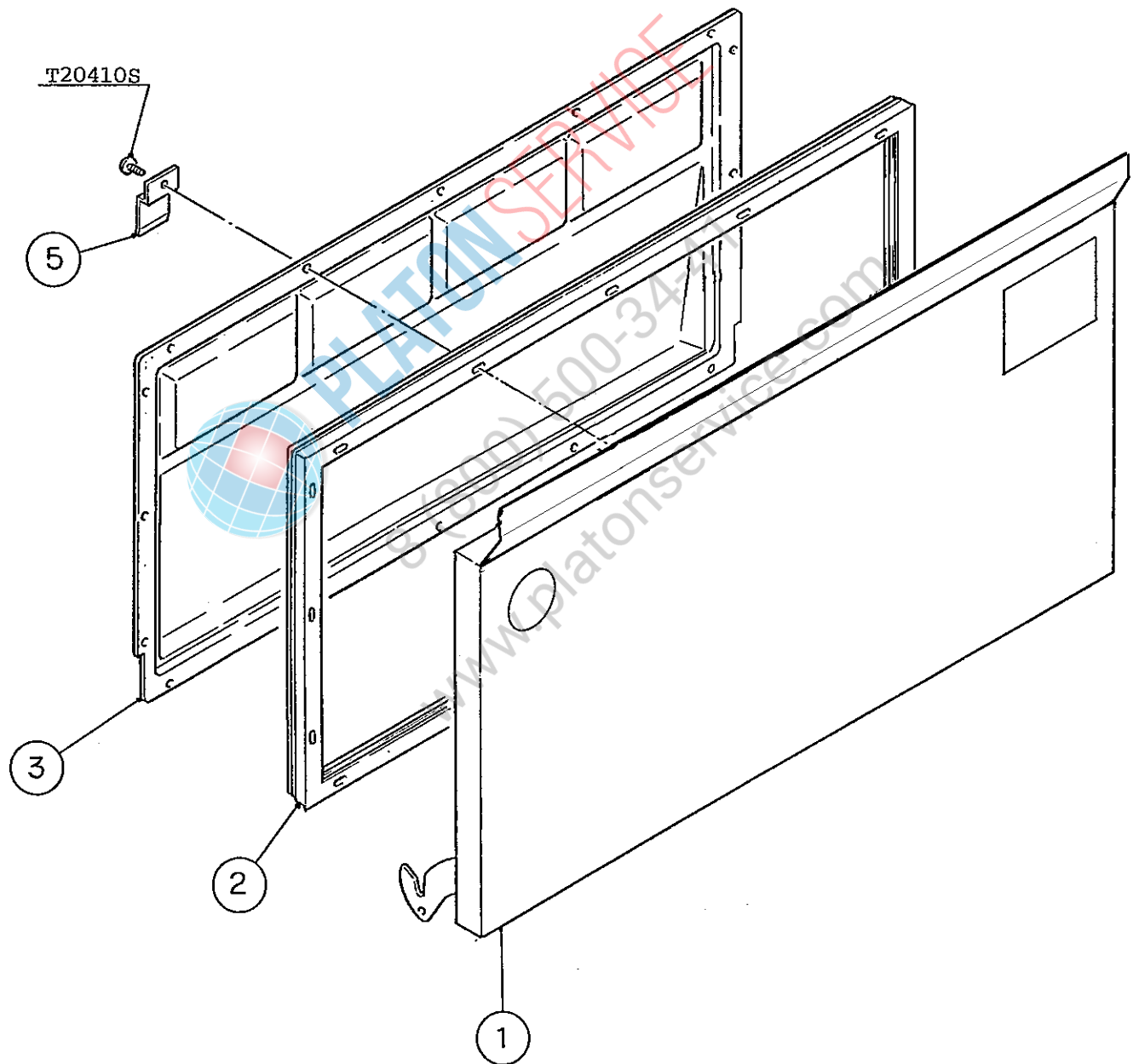

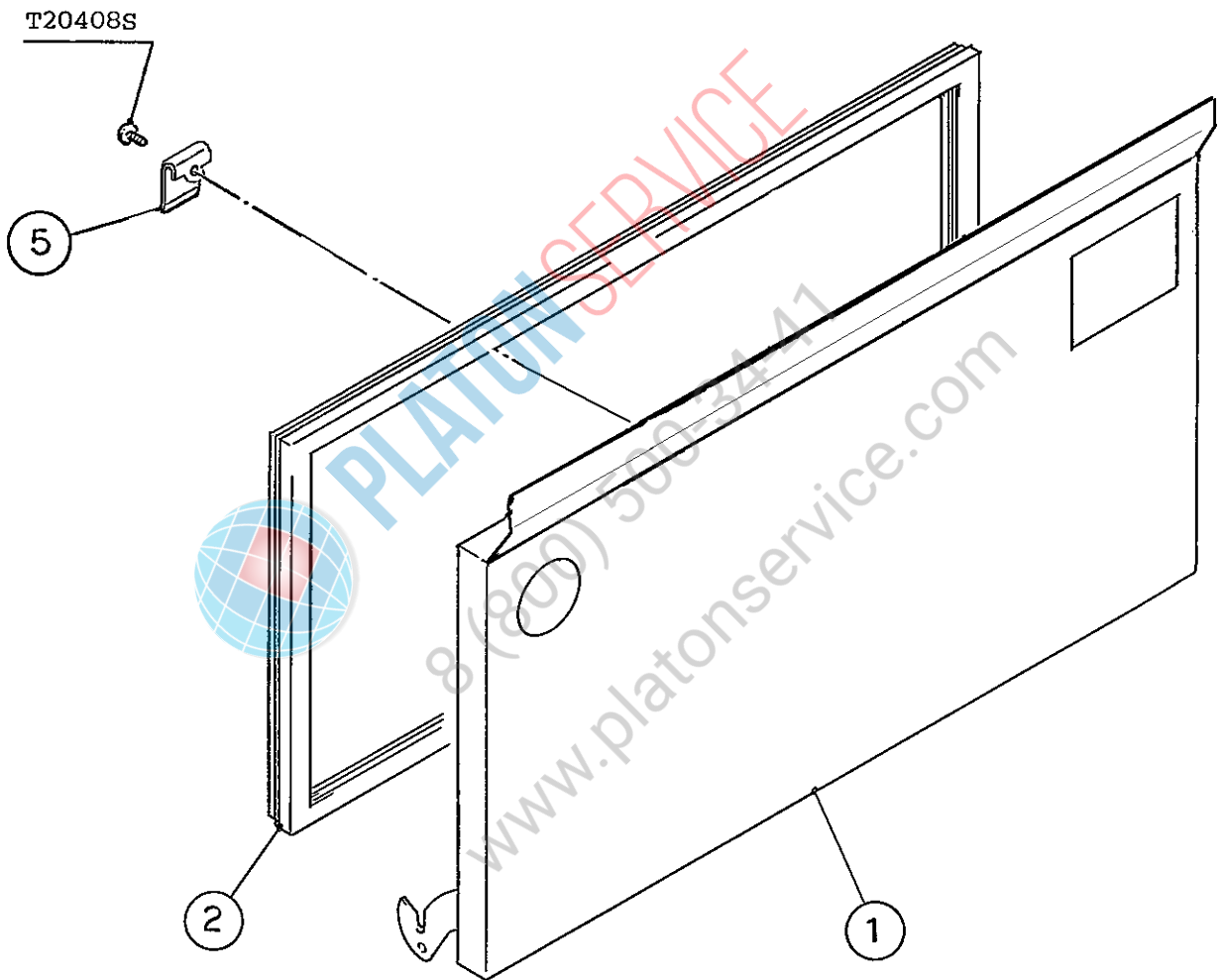







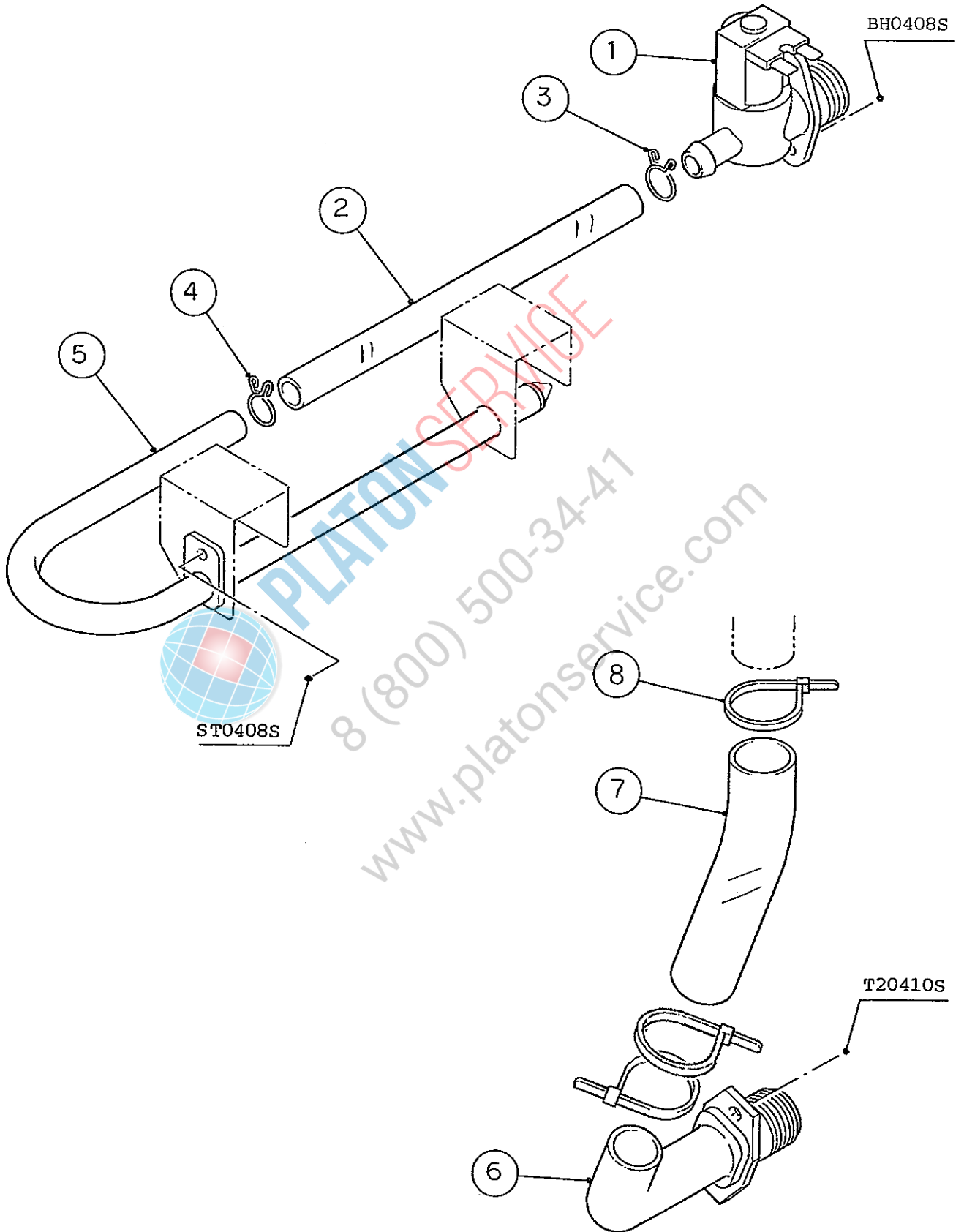







**HE, GENERAL, EXPORT, KOREA, RINNAI, OCEANIA**

MODEL : IM-65WLE, IM-65WLE-25     TITLE : F. WATER CIRCUIT ASSY							
INDEX NO.	DESCRIPTION	MATERIAL OR MODEL NUMBER	PART NUMBER	REQ'D NUMBER			
				E-2 F-0 G-01	G-11	H-11 T-1,U-0 V-0,L-0	
1	WATER SOLENOID VALVE	V18, 5.0 lit / min.	452139-01	1	1	1	
2	SILICONE HOSE	12 ID x 15 OD, L=320	3H9589-03	1	1	1	
3	CLAMP	SK-15	435934-03	1	1	1	
4	CLAMP	SK-14	433909-01	1	1	1	
5	WATER SUPPLY PIPE	ABS	3H9530G01	1	1	1	
6	DRAIN PIPE	PVC	3H0394-01	1	1	1	
7	HOSE	7711-2226, L=135	3H9589-10	1	1	1	
8	TIE	CV-150	7920-0003	3	3	3	

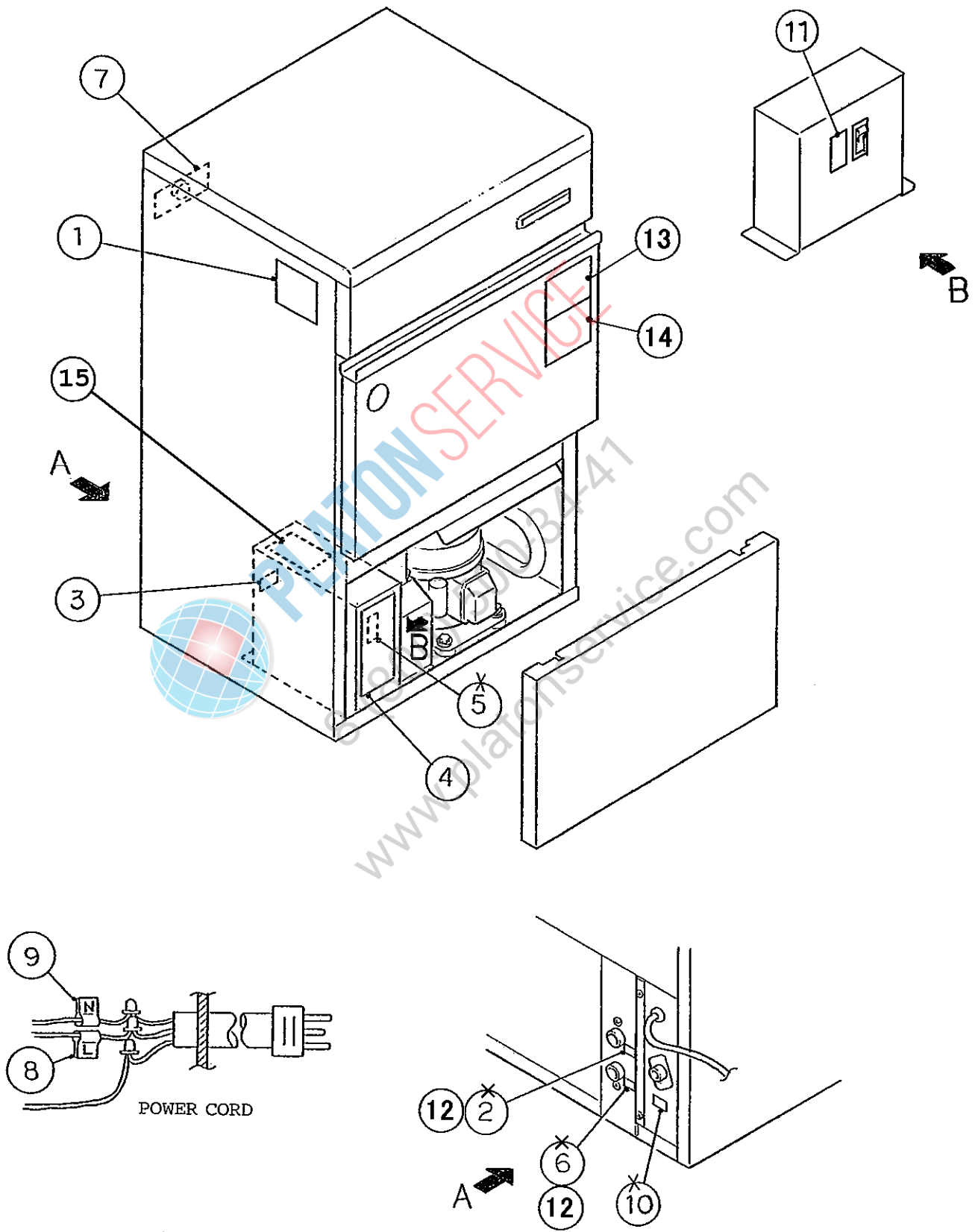

**HE, GENERAL, EXPORT, KOREA, RINNAI, OCEANIA**

MODEL : IM-65WLE, IM-65WLE-25 TITLE : G. LABEL LOCATION							
INDEX NO.	DESCRIPTION	MATERIAL OR MODEL NUMBER	PART NUMBER	REQ'D NUMBER			
				G-1 H-0	H-1 J-0 K-0	K-1 A-0	B-1 C-0
1	NAMEPLATE	PES FILM	N/A	1	1	1	1
2	LABEL - INLET	PES FILM	418029-04	1	1	1	×
3	LABEL - GROUND	PVC FILM	451712-01	1	1	1	1
4	LABEL - CONTROL	(HE)(GENERAL) (OCEANIA)	337911-01	1	—		
		(RINNAI)(EXPORT)	340941-01		1	1	1
		(KOREA)	463007-01				1
5	LABEL - VOLUME	PVC FILM	4X3839-01	1	1	×	
6	LABEL - OUTLET	PES FILM	418029-05	1	1	1	×
7	CAUTION LABEL	PVC FILM	452552-01	1	1	1	1
8	LABEL - TERMINAL	PAPER	452379-03	1	1	1	1
9	LABEL - TERMINAL	PAPER	452379-04	1	1	1	1
10	LABEL - DRAIN WATER	PES FILM	418029-01	1	1	×	
11	LABEL - SWITCH	PVC FILM	454374-01		1	1	1
12	LABEL - CONNECTION	PVC FILM	464541-01				1
13	CAUTION LABEL	(KOREA)	463589-01				1
14	CAUTION LABEL	(KOREA)	463590-01				1



**HE, GENERAL, EXPORT, KOREA, RINNAI, OCEANIA**

MODEL : IM-65WLE, IM-65WLE-25 TITLE : G. LABEL LOCATION							
INDEX NO.	DESCRIPTION	MATERIAL OR MODEL NUMBER	PART NUMBER	REQ'D NUMBER			
				E-2 F-0 G-01	G-11	H-11 T-1,U-0 V-0,L-0	
1	NAMEPLATE	PES FILM	N/A	1	1	1	
2	-	-	-				
3	LABEL - GROUND	PVC FILM	451712-01	1	1	1	
4	LABEL - CONTROL	(HE)(GENERAL) (OCEANIA) (RINNAI)(EXPORT)	340941-01	1	1	1	
		(KOREA)	463007-01	1	1	1	
5	-	-	-				
6	-	-	-				
7	CAUTION LABEL	PVC FILM	452552-01	1	1	1	
8	LABEL - TERMINAL	PAPER	452379-03	1	1	1	
9	LABEL - TERMINAL	PAPER	452379-04	1	1	1	
10	-	-	-				
11	LABEL - SWITCH	PVC FILM	454374-01	1	1	1	
12	LABEL - CONNECTION	PVC FILM	464541-01	1	1	1	
13	CAUTION LABEL	(KOREA)	463589-01	1	1	1	
14	CAUTION LABEL	(KOREA)	463590-01	1	1	1	
15	LABEL - CONTROLLER BOARD	PVC FILM	467627-01	1	1	1	

(S-0867)

(D-2) (E-0) (E-1) and later

(C-0) (C-1) (D-0) (D-1)

(K-0) (K-1) (A-0) (B-1)

(G-1) (H-0) (H-1) (J-0)

IM-65WLE, 65WLE-25

H. FITTING (P) ASSY

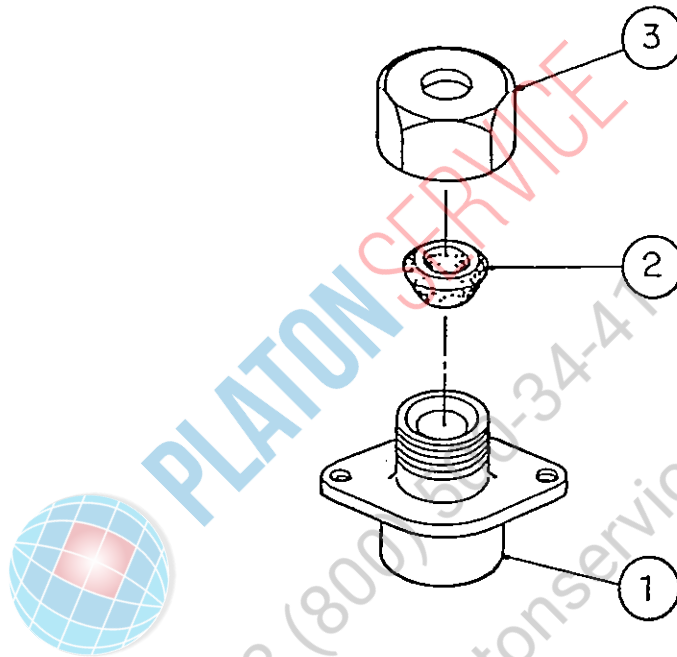



**HE, GENERAL, EXPORT, KOREA, RINNAI, OCEANIA**

MODEL : <b>IM-65WLE, IM-65WLE-25</b> TITLE : <b>H. FITTING (P) ASSY</b>							
INDEX NO.	DESCRIPTION	MATERIAL OR MODEL NUMBER	PART NUMBER	REQ'D NUMBER			
				C-1 D-0	D-1	D-2 E-0	E-1
1	FITTING (K)	BRASS	3H7961-01	1	1	1	1
2	TAPER PACKING (A)	SY.R	415715-01	1	1	1	1
3	NUT (A) - FITTING	BRASS	415713-01	1	1	1	1

PLATON SERVICE

8 (800) 500-34-47

www.platonservice.com







(S-0817)

(D-2) (E-0) (E-1) and later

(C-0) (C-1) (D-0) (D-1)

(K-0) (K-1) (A-0) (B-1)

(G-1) (H-0) (H-1) (J-0)

IM-65WLE, 65WLE-25 J. BIN CONTROL SWITCH ASSY

